

# BR70

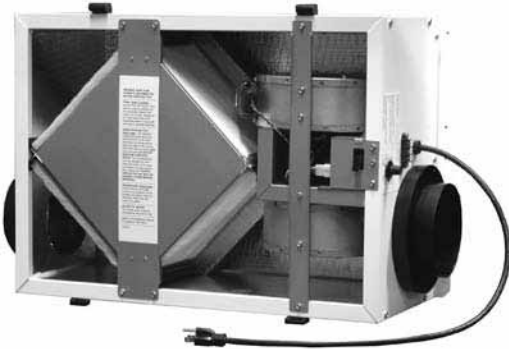

## Indoor Unit - Duct Mounted or Thru-the-Wall



## Specifications

Ventilation Type: Static Plate, Heat and Humidity Transfer				
Typical Airflow Range: 40-70 CFM				
Number Motors: One, 0.08 hp				
V	HZ	Phase	Input Watts	FLA
120	60	Single	94 @ 69 CFM	0.9
Control: Built in proportional runtime control and switched terminals for furnace/AC interconnect				
Filters: MERV 8, spun polyester media. 7-1/2" x 10-1/2" x 1"				
Weight: 39 lbs (unit), 50 lbs (in carton)				
Shipping Dimensions: 29" L x 21-1/2" W x 14-1/2" H (in carton)				
Options: Thru-the-Wall Kit Duct Collar Kit See I&O Manual on the web site for details.				

## G5 Performance

Airflow CFM	ESP in H <sub>2</sub> O	Temp EFF%	Total EFF% Winter/Summer*
46	0.40	80	75/62
59	0.30	77	72/58
73	0.20	75	69/54
86	0.10	72	66/51

\* (See HVI certification report on page 66 for complete certified rating).

## Dimensions

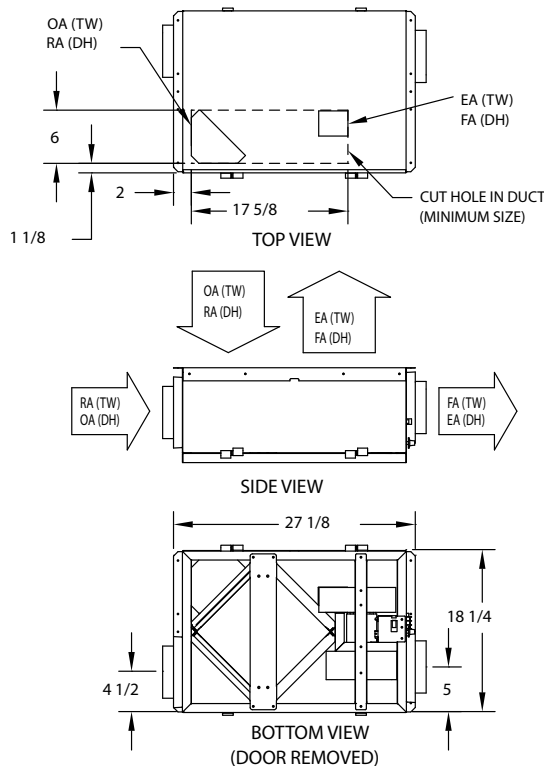

EA: Exhaust Air to outdoors  
 OA: Outdoor Air intake  
 RA: Room Air to be exhausted  
 FA: Fresh Air to inside  
 TW: Thru Wall  
 DH: Duct Hung

