

BR70

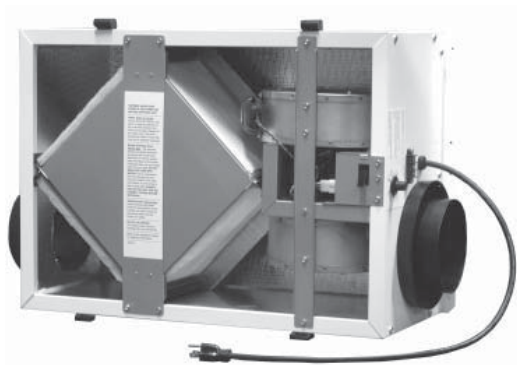

Indoor Unit



Specifications

Ventilation Type: Static Plate, Heat and Humidity Transfer				
Typical Airflow Range: 40-70 CFM				
Number Motors: One, 0.08 hp				
V	HZ	Phase	Input Watts	FLA
120	60	Single	94 @ 69 CFM	1.0
Control Voltage: 24 VAC				
Filters: Cleanable, spun polyester media. 7 1/2" x 10 1/2" x 1"				
Weight: 45 lbs (unit), 55 lbs (in carton)				
Shipping Dimensions: 21 1/2"W x 29"L x 13"H				
Options: Thru-the-Wall Kit Duct Collar Kit				

G4 Performance

Airflow CFM	ESP in H ₂ O	Temp EFF%	Total EFF% Winter/Summer*
35	0.50	84	75/60
51	0.40	80	71/56
63	0.30	77	68/53
71	0.25	75	66/50
79	0.20	73	64/48
90	0.10	70	61/45

* (See HVI certification report on page 11 for complete certified rating).

Dimensions

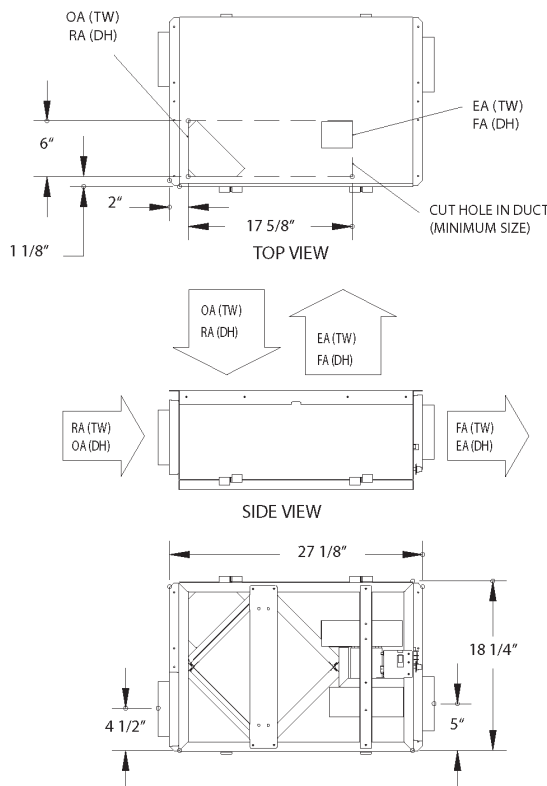

EA: Exhaust Air to outdoors
 OA: Outdoor Air intake
 RA: Room Air to be exhausted
 FA: Fresh Air to inside

TW: Thru Wall
 DH: Duct Hung

