

# BR130

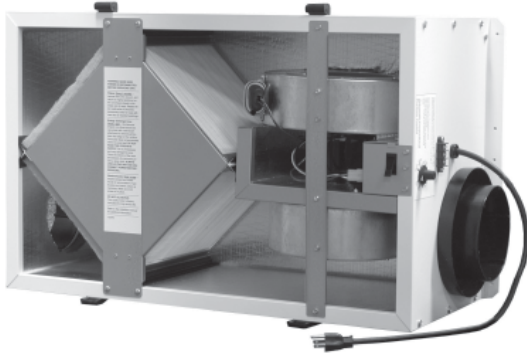

## Indoor Unit



## G4 Performance

Airflow CFM	ESP in H2O	Temp EFF%	Total EFF% Winter/Summer*
52	0.70	83	75/60
69	0.60	80	72/57
94	0.50	76	67/52
113	0.40	73	64/48
124	0.35	71	62/46
132	0.30	70	60/44
141	0.20	68	59/43
148	0.10	67	57/41

\* (See HVI certification report on page 11 for complete certified rating).

## Dimensions

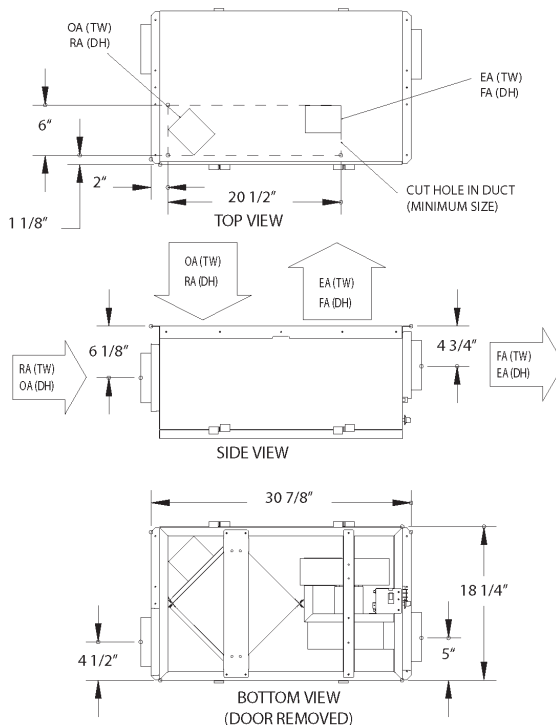

EA: Exhaust Air to outdoors  
 OA: Outdoor Air intake  
 RA: Room Air to be exhausted  
 FA: Fresh Air to inside  
 TW: Thru Wall  
 DH: Duct Hung

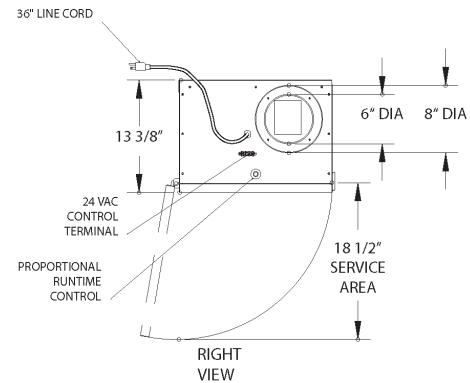

## Specifications

Ventilation Type: Static Plate, Heat and Humidity Transfer				
Typical Airflow Range: 50-140 CFM				
Unit may be mounted in any orientation				
Number Motors: One, 0.07 hp				
V	HZ	Phase	Input Watts	FLA
120	60	Single	121 @ 124 CFM	1.3
Control Voltage: Built in proportional runtime control and switched terminals for furnace / AC interconnect				
Filters: Cleanable, spun polyester media. 10 1/2" x 10 1/2" x 1"				
Weight: 55 lbs (unit), 65 lbs (in carton)				
Shipping Dimensions: 21 1/2"W x 32"L x 15 1/2"H				
Options: Thru-the-Wall Kit Duct Collar Kit				