

# RD2XRT INSTALLATION AND OPERATION MANUAL

# BOOK 2

## SPECIFICATIONS

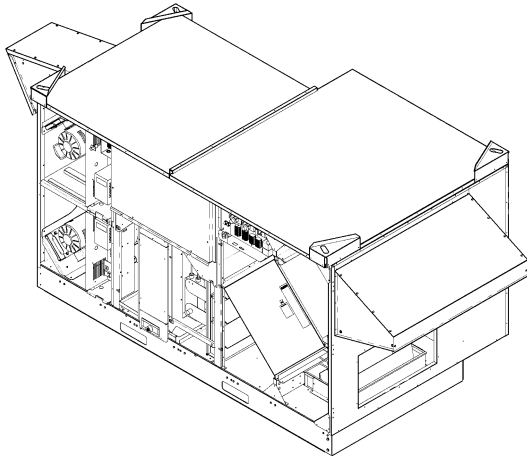

### ABOUT BOOK 2:

This book provides the basic specifications of the RD2XRT.

Please see Book 1 for an overview of the RD2XRT and system design considerations.

See Book 3 for the mechanical installation of the RD2XRT.

See Book 4 for basic electrical connections and wiring schematics.

See Book 5 for control system connections, VFD adjustment, Start-Up, Commissioning or Maintenance.

This book does not cover overall system design or system integration issues. Some of these issues are discussed in Books 1 and 5, but in general, specification documents provided by a qualified specifying engineer are to be considered the Basis of System Design.

Following these instructions does not necessarily assure compliance with local codes and standards, which must always be observed.

## Table of Contents

### BOOK 1: Overview

Product Features	2
De-Coupled and DOAS System Overview	3
RD2X Psychrometrics	4
Systems Integration	6
Critical Warnings	7
Checklist for Specifying Engineer	8

### BOOK 2: Specifications

Product Features	2
Available Features	3
Descriptive Drawings	4
Configuration Codes	6
Condensed Specifications	8
Energy Recovery Performance	8
Control Ranges and Setpoints	9
Disconnect Switch Ratings	9
Dimensions	10
Corner Weights and Curb Dimensions	11
Airflow and Power Ratings	12
Airflow and Power	12
Coil Pressure Drop	12
Chart of Coil Types and Identification Codes	12
Modes of Operation	13
Unit Controls and Operating Sequences	14
Connections to External Equipment	16
Guide Specifications	17

### BOOK 3: Mechanical Installation

Product Features	2
Order of Installation	3
Critical Dimensions	4
Curb and Rail Dimensions	5
Service Clearances	6
Curb and Rail Installation Considerations	7
Rigging Information	8
Securing the Unit Against Wind Loads	9
Ducting	10
Coil and Drain Connections	11
How to Reconfigure the Inlet and Outlet (opt.)	12
How to Install Field-Supplied Coil (opt.)	14

### BOOK 4: Electrical Installation

Product Features	2
Power Connections	3
Disconnect Switch Ratings	5
On-Board Transformer	6
Control Connections	7
Electrical Installation Checklists	8
Schematics	10
Ladder Schematics	18

### BOOK 5: Start-Up, Commissioning and Maintenance

Initial Checks	3
Balance Air Flow	4
Review / Adjust On-Board Controls (opt.)	6
VFD Parameters	8
Control Connection Examples: On/Off and 3-speed	11
Analog Control of the VFDs -- General	16
Scaling to VFD Response to Analog Inputs	17
Control Connection Examples: Analog Controllers	22
Control Connection Examples: Mixed Analog & On/Off	35
To Reset VFD Parameters	39
Service Parts	40
Warranty Information	48
Records	49

# BOOK 2: SPECIFICATIONS

## PRODUCT FEATURES

The RD2X is an Energy Recovery Ventilator with available features designed for Dedicated Outdoor Air Systems.

Standard features include:

- Energy recovery by fixed-plate enthalpic energy exchanger
- Enthalpy- and temperature-controlled bypass of energy recovery
- Isolation dampers that shut down when ventilation is not needed
- Variable-Frequency Drive (VFD)-controlled direct-drive fresh air and exhaust air blowers
- Integrated disconnect switch
- Airflow measurement stations

Available features include:

- Heating and/or cooling coils for post-treatment of fresh air
- Double-wall construction

### PRINCIPLE OF OPERATION

The RD2X can operate in up to four modes depending on options installed:

- Energy Recovery mode: the unit transfers heating or cooling energy from the exhaust air to the fresh air.
- Recovery Bypass mode: the unit takes advantage of free cooling from the outside air and doesn't transfer energy between air streams.
- Dehumidification mode: the unit conditions the fresh air to 53°F.
- Heating mode: the unit tempers the fresh air to 75°F.

The RD2X operates automatically. The unit receives an external call for ventilation. Its isolation dampers open and turn on the variable frequency drives and blowers. The unit determines the operating mode by continuously monitoring the air streams for temperature and enthalpy.

The RD2X does not include a condensing unit, chiller, heat pump or boiler. When a coil for dehumidification or cooling is part of the RD2X unit, the condensing unit, chiller, heat pump or boiler is separately installed to meet the needs of the complete system. RD2X units equipped with coils include connection points to call for operation of the separate heating or cooling equipment. **However, no fluid or refrigerant flow control valve (TX valve) is provided, and must be specified by the designer of the overall system for separate sourcing.**

### OPERATING CONTROLS

A wide variety of low voltage (24VAC) control schemes may be selected to meet the ventilation needs of the facility. These may include time clock, occupancy sensor, carbon dioxide sensor, and others. DDC systems may also control the unit with external control by other. **TX valves are not provided.**

## WARNING

### RISK OF FIRE, ELECTRIC SHOCK, OR INJURY.

#### OBSERVE ALL CODES AND THE FOLLOWING:

1. Before servicing or cleaning the unit, switch power off at disconnect switch or service panel and lock-out/tag-out to prevent power from being switched on accidentally. More than one disconnect switch may be required to de-energize the equipment for servicing.
2. This installation manual shows the suggested installation method. Additional measures may be required by local codes and standards.
3. Installation work and electrical wiring must be done by qualified professional(s) in accordance with all applicable codes, standards and licensing requirements.
4. Any structural alterations necessary for installation must comply with all applicable building, health, and safety code requirements.
5. This unit must be electrically grounded.
6. Sufficient air is needed for proper combustion and exhausting of gases through the flue (chimney) of fuel burning equipment that might be installed in the area affected by this equipment. If this unit is exhausting air from a space in which chimney-vented fuel burning equipment is located, take steps to assure that combustion air supply is not affected. Follow the heating equipment manufacturer's requirements and the combustion air supply requirements of applicable codes and standards.
7. Use the unit only in the manner intended by the manufacturer. If you have questions, contact the manufacturer.
8. This unit is intended for general ventilating only. Do not use to exhaust hazardous or explosive materials and vapors. Do not connect this unit to range hoods, fume hoods or collection systems for toxics.
9. Danger of severe injury to bystanders and damage to unit or property if high winds move this unit. Secure this unit to the building!

## CAUTION

**To avoid motor bearing damage and noisy and/or unbalanced impellers, keep drywall spray, construction dust etc, out of unit.**

# BOOK 2: SPECIFICATIONS

## AVAILABLE FEATURES

### DIRECT EXPANSION (DX) DEHUMIDIFICATION COIL

The RD2XRT can be ordered with a direct expansion (DX) coil for dehumidification. The coil is ARI-certified for R22, and UL-listed. The coil comes uncharged; R-22 or R-410A refrigerant can be used.

5-row and 3-row single circuit coils, and 4-row and 3-row dual circuit coils are available.

These coils can be ordered in combination with our hot water heating coil if desired. **Refrigerant flow control valve (TX valve) is not provided.**

### DIRECT EXPANSION (DX) COIL FOR HEAT PUMP

The RD2XRT can be ordered with a direct expansion (DX) coil for dehumidification and/or heating by a heat pump. These high-pressure coils are UL-listed. The coil comes uncharged; R-22 or R-410A refrigerant can be used.

4-row and 3-row single-circuit and dual-circuit coils are available. **Refrigerant flow control valve (TX valve) is not provided.**

### CHILLED WATER DEHUMIDIFICATION COIL

The RD2XRT can be ordered with a 5-row, 4-row, or 3-row water coil for dehumidification. The coil is ARI certified and UL listed.

These coils can be ordered in combination with our hot water heating coil if desired. **Flow control valve (zone valve) is not provided.**

### HOT WATER HEATING COIL

The RD2XRT can be ordered with a 1-row water coil for heating. The coil is ARI certified and UL listed. **Flow control valve (zone valve) is not provided.**

#### NOTE: COIL CONNECTIONS

Access Panels in the back of the RD2XRT allow for piping the coil connections either through the back of the unit or down through the bottom of the unit, inside the curb.

### NO COIL WITH DRAIN PANS

Should you desire, the RD2XRT can also be ordered without any coil but with drain pans installed. This might be the case if a coil is to be installed in the field.

### NO COIL WITHOUT DRAIN PANS

The RD2XRT can also be ordered without any coil and without drain pans.

### DRY BULB CONTROL

The RD2XRT offers a temperature controller that senses dry bulb temperature of the air. The temperature controller set point is field adjustable for your specific application.

### BYPASS INDICATION

The RD2XRT allows connection for remote indication when the unit goes into bypass mode.

### FILTER ALARM

RenewAire can provide a filter alarm system. The purpose is to provide a remote indication that the filters have become fully loaded and need replacement. The filter alarm system consists of two adjustable differential pressure switches, one in each airstream that measures static pressure upstream and downstream of each filter. Connect the pressure switches to a remote indicator.

### EXTERNAL CONTROLS

RenewAire offers separately the following for stand-alone control of the RD2XRT:

- Digital Time Clocks TC7D-W and TC7D-E
- Occupancy Sensors MC-C and MC-W.
- Carbon Dioxide Sensor/Controllers CO2-W and CO2-D.

### BMS INTERFACE

The RD2XRT can interface with a Building Management System (BMS) for control of the unit. The BMS needs to supply the RD2XRT with a "Call for Ventilation" signal, in the form of a dry contact relay. The BMS may also supply at least one "Frequency" signal, either in the form of dry contact relays calling on preset speeds in the VFD(s), or in the form of an analog signal (0-10vdc or 4-20mA).

# BOOK 2: SPECIFICATIONS

## DESCRIPTIVE DRAWINGS

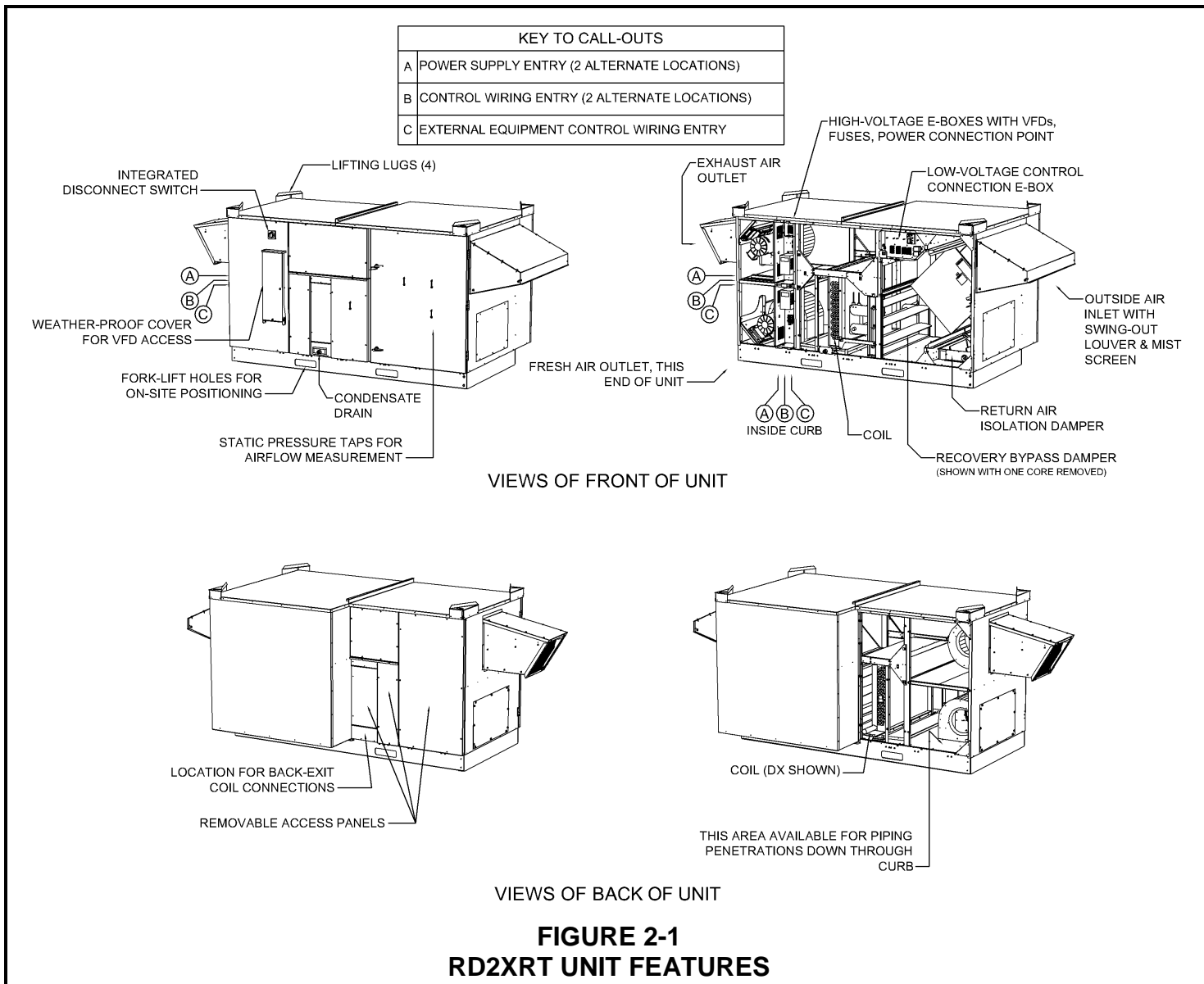

# BOOK 2: SPECIFICATIONS

## DESCRIPTIVE DRAWINGS

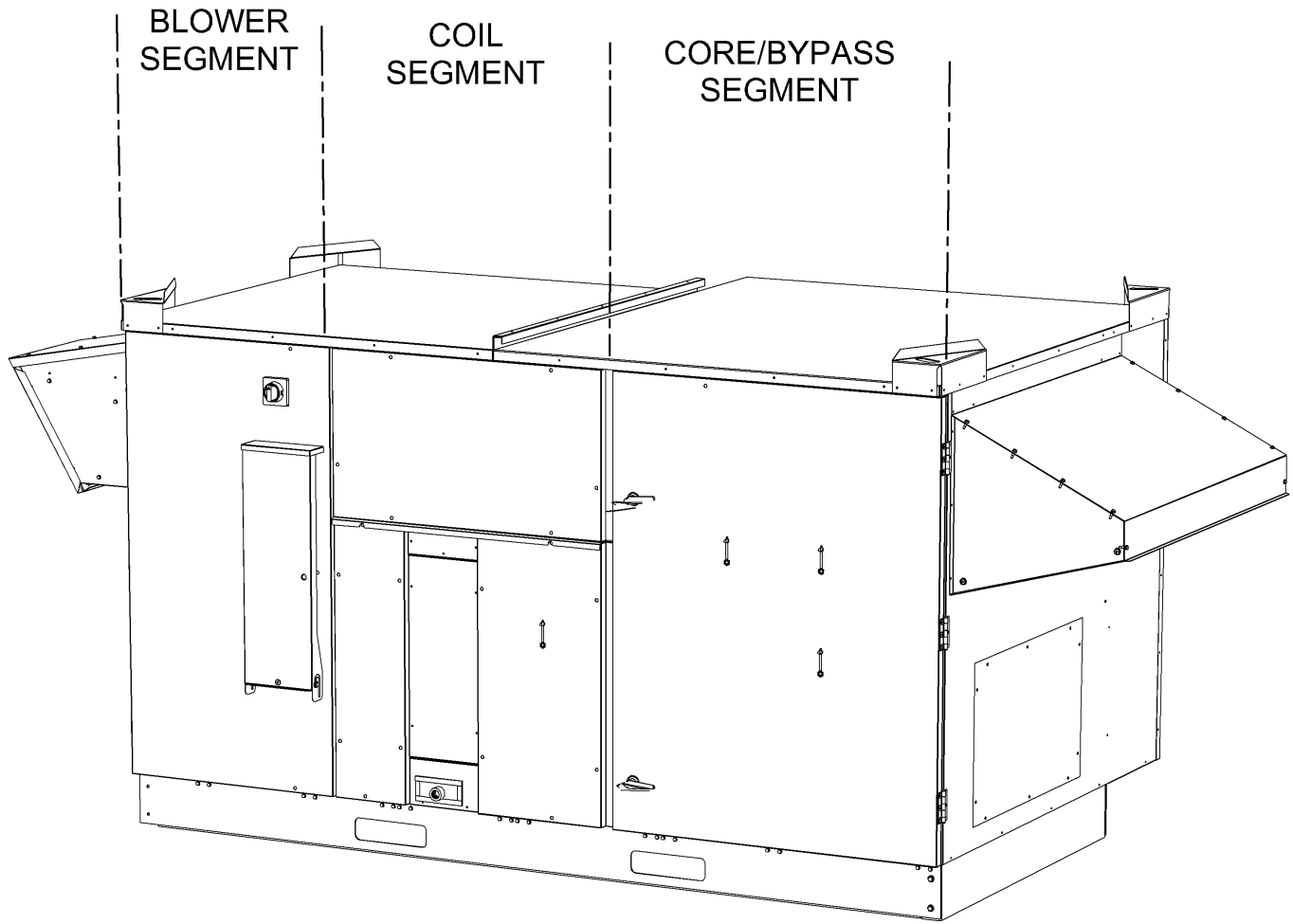

VIEWED FROM FRONT OF UNIT

FIGURE 2-2  
RD2XRT UNIT SEGMENTS

# BOOK 2: SPECIFICATIONS

## CONFIGURATION CODES

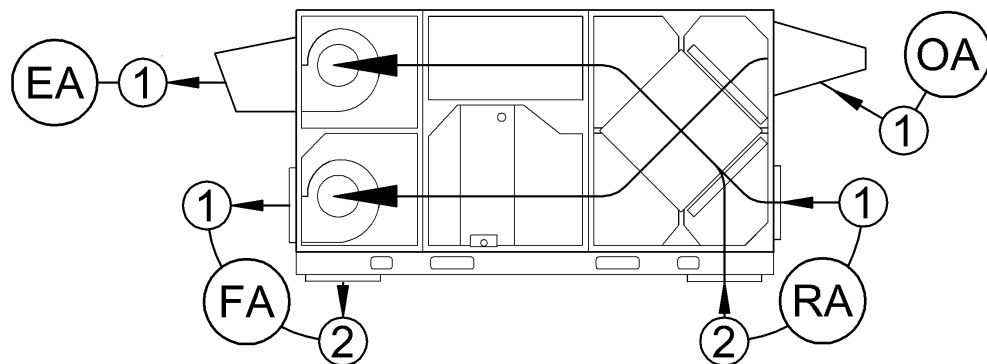

KEY TO AIRFLOW CODES	
OA	Outside Air into Unit
RA	Room Air into Unit
FA	Fresh Air from Unit
EA	Exhaust Air Leaving Unit

KEY TO CONFIGURATION CODES				
OA	RA	FA	EA	CODE
1	1	1	1	A
1	1	2	1	C
1	2	1	1	E
1	2	2	1	G

FIGURE 2-3

INLET/OUTLET CONFIGURATIONS OPTION CODES FOR RD2XRT UNITS  
SEE ALSO CHART OF ALL AVAILABLE INLET/OUTLET CONFIGURATIONS, FIG 2-7, NEXT PAGE

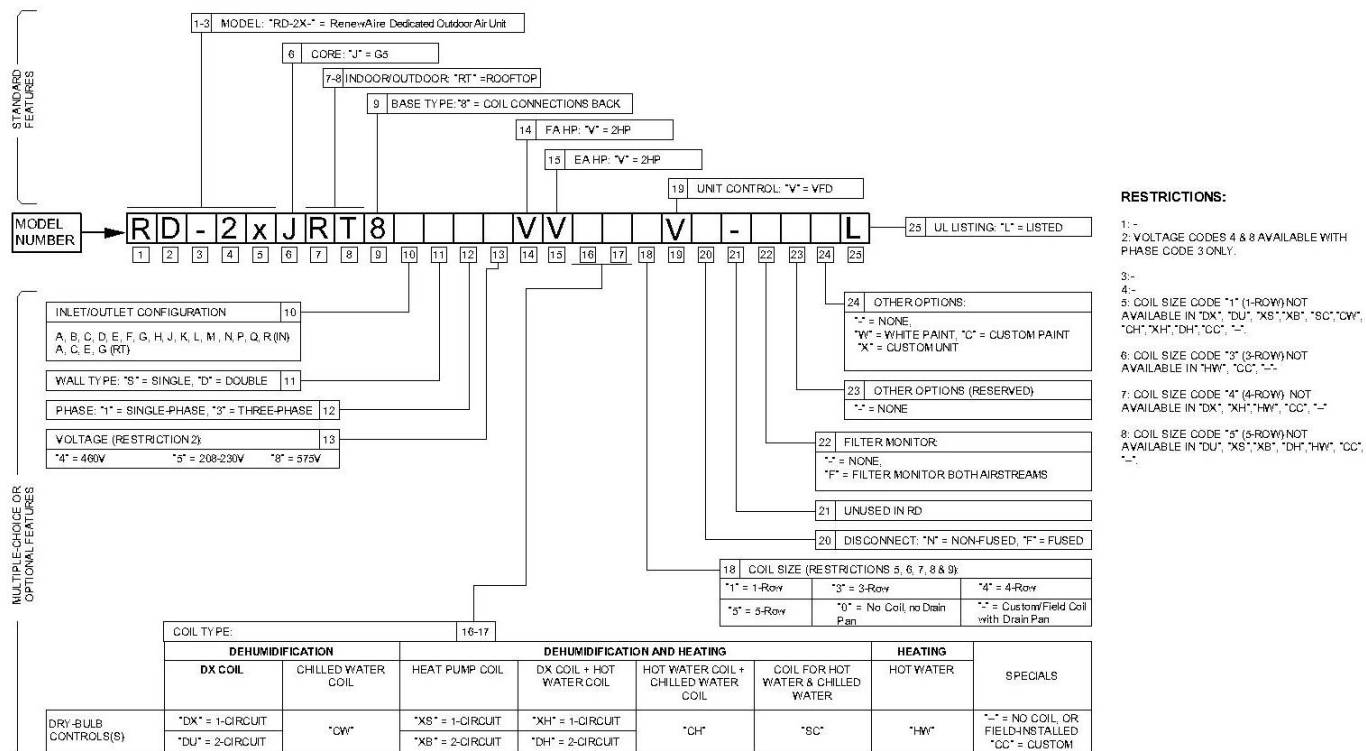
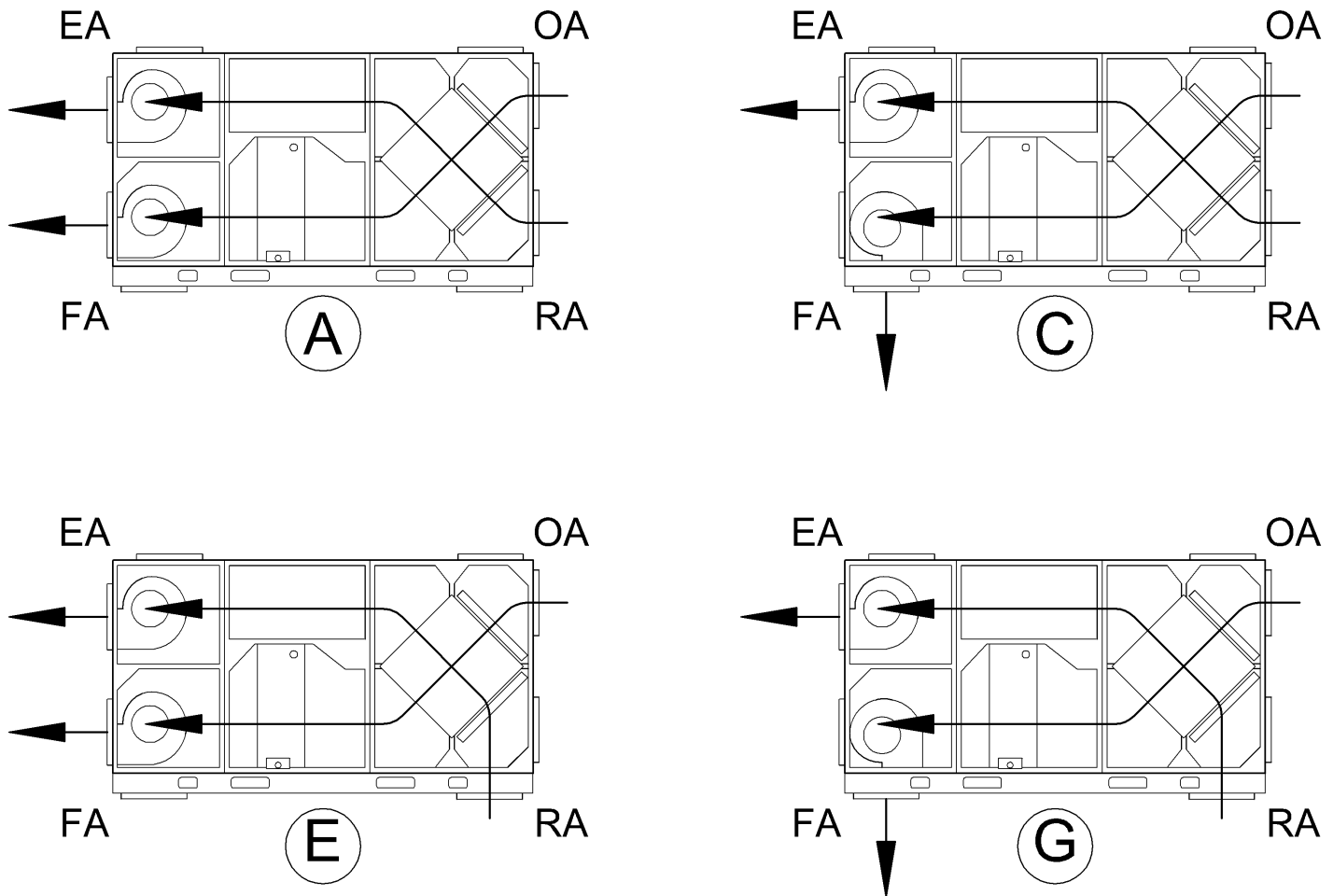

FIGURE 2-4: DIRECTORY TO RD2XRT MODEL NUMBERS

# BOOK 2: SPECIFICATIONS

## CONFIGURATION CODES



**FIGURE 2-5**  
**CHART OF ALL AVAILABLE INLET/OUTLET CONFIGURATIONS FOR RD2XRT**  
**CIRCLED LETTERS (A, C, E & G) INDICATE THE CONFIGURATION CODES**

# BOOK 2: SPECIFICATIONS

## CONDENSED SPECIFICATIONS

### SPECIFICATIONS

<b>Model: RD2XRT</b>						
Ventilation Type: Static Plate, Heat and Humidity Transfer						
Typical Air Flow Range: 500 – 2200 CFM						
ARI 1060 Certified Core: (2) L125 G5						
Air Flow at Certified Rating Points: 1500 CFM and 1126 CFM						
Blowers/Motors: (2) Direct-drive DWDI centrifugal blowers, with premium efficiency inverter-rated 2HP motors.						
ELECTRICAL RATINGS						
Input Voltage	Phase (Unit)	MCA (Unit)	MFS (Unit)	FLA (VFD)	FLA (Motor)	Motor Efficiency
208-230	1	21.4	30	9.5	6.0-5.8	86.5%
208-230	3	18.2	20	8.1	6.0-5.8	86.5%
460	3	9.2	15	4.1	2.9	86.5%
575	3	7.2	15	3.2	2.3	84.0%
Inlets/Outlets: 14" x 24"						
Filters: (5) total, 2" pleated MERV 8; RA : (2) 20" x 20" nominal OA: (2) 20" x 20" nominal, (1) 20" x 14" nominal						
Weight: 1158 lbs (unit), 1260 lbs (shipping)*						
Shipping dimensions: 94" x 116" pallet, 54" high						

\* Weight varies with options installed.

### ENERGY RECOVERY PERFORMANCE

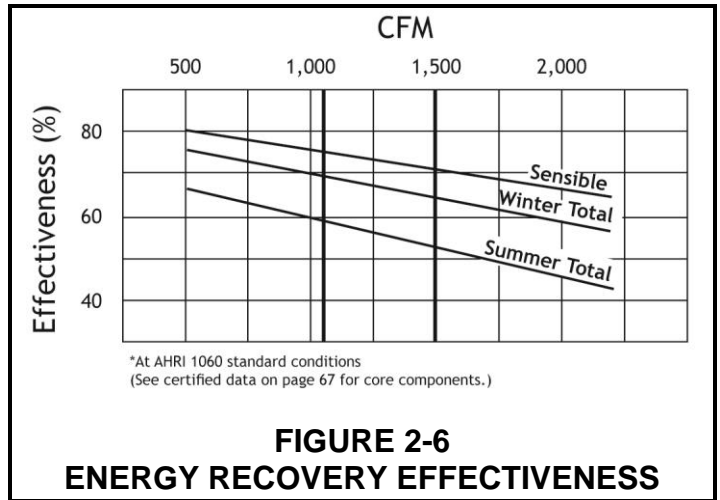

**FIGURE 2-6**  
**ENERGY RECOVERY EFFECTIVENESS**

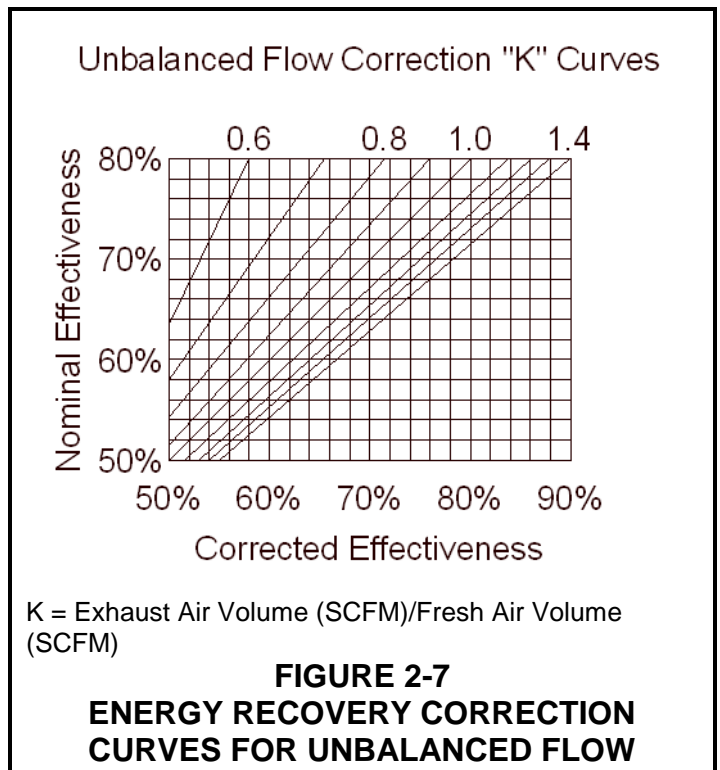



# BOOK 2: SPECIFICATIONS

## CONDENSED SPECIFICATIONS

### CONTROL RANGES & SETPOINTS

Control	Range	Factory Setting
OA/RA Differential Enthalpy	n/a	28 BTU
OA Bypass Low Limit Temperature	-20°F to 120°F	55°F
Dehumid Coil Low Limit Dry Bulb Temperature	-20°F to 120°F	53°F
Heat Coil High Limit Dry Bulb Temperature	-20°F to 120°F	50°F

### DISCONNECT SWITCH

RD2X unit has an integrated Disconnect Switch with a door interlock. The door covering the high-voltage and motor compartments cannot be opened without turning this Disconnect Switch to the "OFF" position.

Once the door is opened, the Disconnect Switch can be switched back to the "ON" position for trouble-shooting purposes. In this case, the Disconnect Switch must be returned to the "OFF" position in order to close the door.

Local codes may require installation of an additional Disconnect Switch.

<b>RATINGS:</b>	1Ø	3Ø
<b>VOLTAGE:</b>	600VAC	
<b>AMPS:</b>	40A	25A
<b>HORSE POWER:</b>	4HP @ 240V	7.5HP @ 240V
<b>MAXIMUM WIRE SIZE:</b>	6AWG	8AWG

#### CHARACTERISTICS:

- Must be in OFF position to open Door covering high-voltage compartments.
- May be returned to ON position after Door is open.
- Available Factory Option: Fuse Block
- Door covering low-voltage electrical compartment can be opened without turning disconnect switch to OFF position.
- When Disconnect Switch is in OFF position, voltage is still available at the L1, L2 and L3 terminals.

# BOOK 2: SPECIFICATIONS

## DIMENSIONS

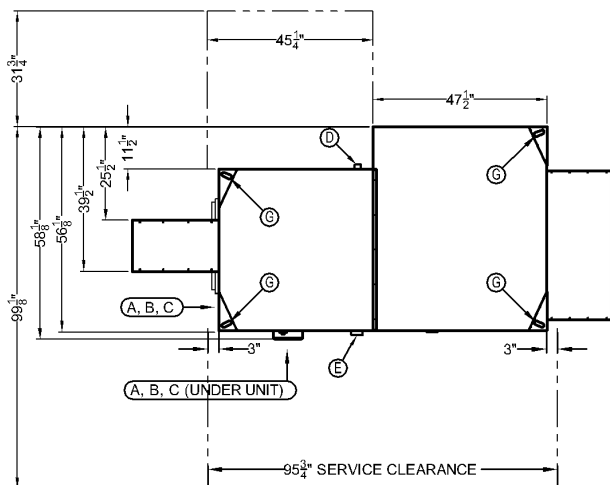

KEY TO CALL-OUTS	
A	POWER CONNECTION 7/8Ø
B	UNIT LOW-VOLTAGE CONTROL CONNECTIONS (2) 3/8"Ø
C	EXTERNAL EQUIPMENT LOW-VOLTAGE CONTROL CONNECTION 1/8"Ø
D	COIL CONNECTIONS - SIZE AND LOCATION VARY
E	CONDENSATE DRAIN
F	VFD ACCESS COVER
G	LIFTING POINTS (4)

KEY TO AIRFLOW CODES	
OA	OUTSIDE AIR INTO UNIT
RA	ROOM AIR INTO UNIT
FA	FRESH AIR FROM UNIT
EA	EXHAUST AIR FROM UNIT

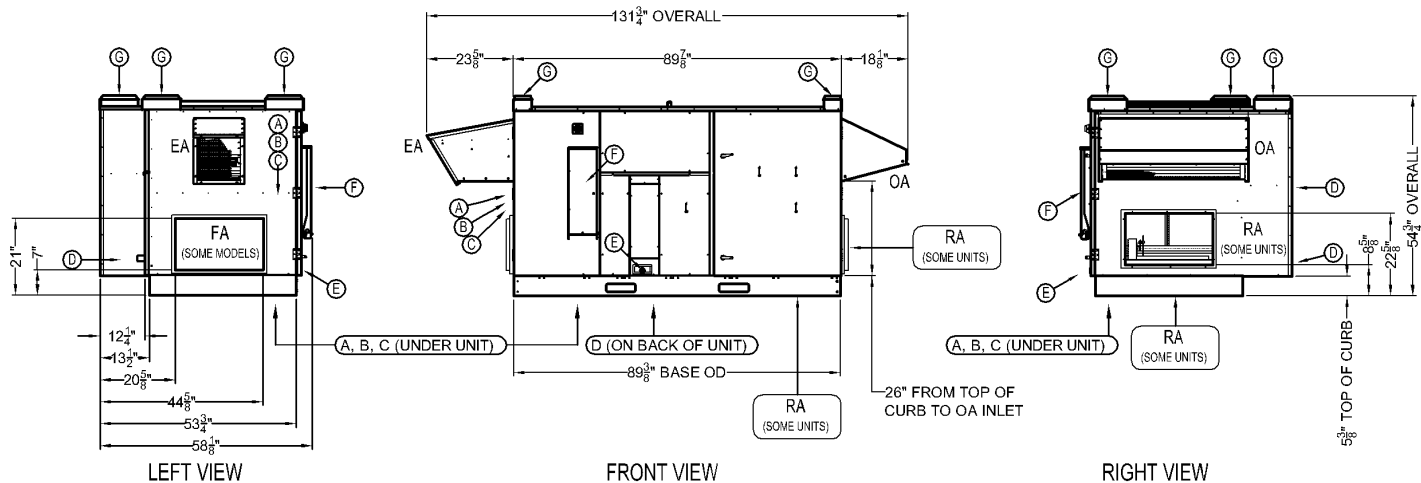
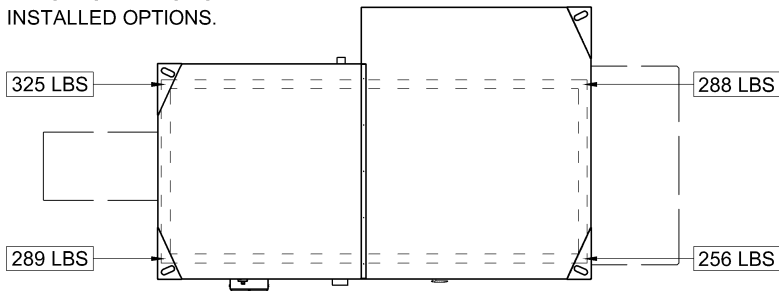

**FIGURE 2-8  
UNIT DIMENSIONS**

# BOOK 2: SPECIFICATIONS

## CORNER WEIGHTS AND CURB DIMENSIONS

WEIGHTS SHOWN AT CENTERLINE OF CURB.  
WEIGHTS VARY SLIGHTLY WITH INSTALLED OPTIONS.



VIEWED FROM ABOVE

**FIGURE 2-9  
UNIT CORNER WEIGHTS ON CURB**

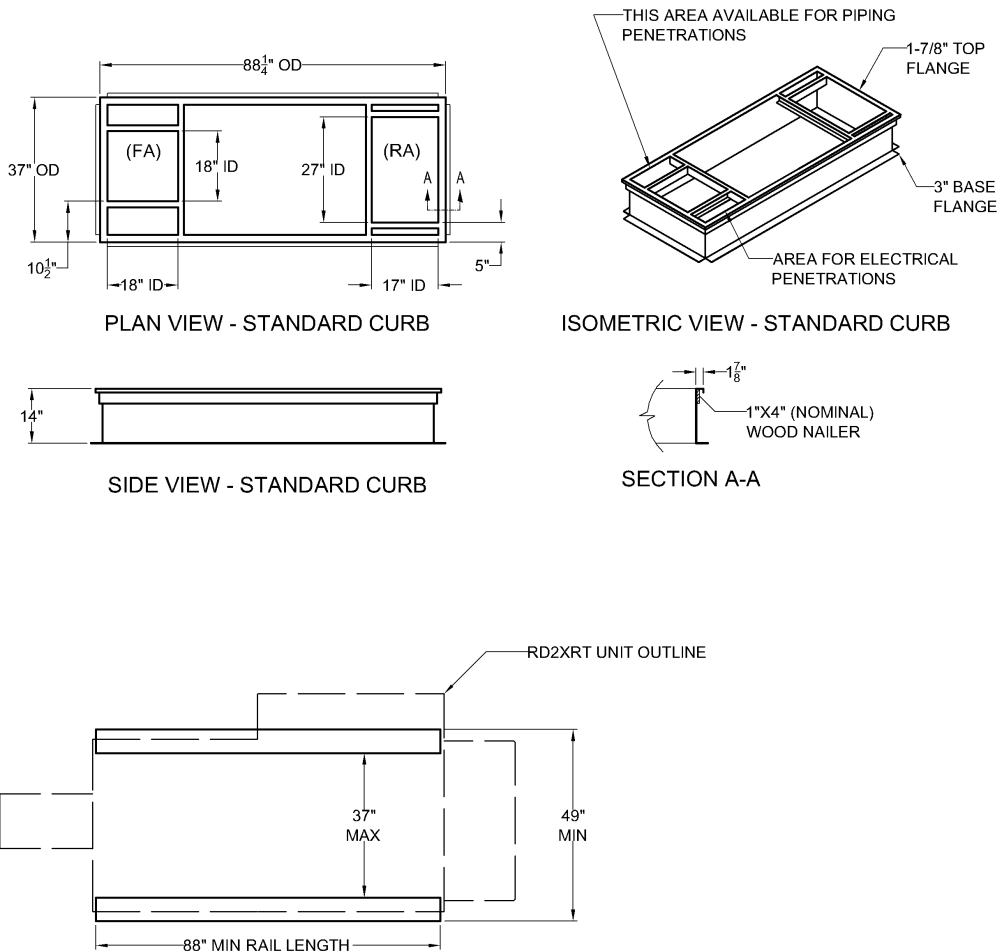

PLAN VIEW - EQUIPMENT RAIL RECOMMENDATIONS

**FIGURE 2-10  
STANDARD CURB DIMENSIONS**

# BOOK 2: SPECIFICATIONS

## AIRFLOW AND POWER RATINGS

### RD2XRT UNIT AIRFLOW WITHOUT COIL(S)

BLOWER VFD HERTZ SETTING	UNIT ESP (in.H <sub>2</sub> O) AND POWER CONSUMPTION (WATTS PER AIRSTREAM)													
	500 CFM		750 CFM		1000 CFM		1250 CFM		1500 CFM		1750 CFM		2000 CFM	
	ESP	WATTS	ESP	WATTS	ESP	WATTS	ESP	WATTS	ESP	WATTS	ESP	WATTS	ESP	WATTS
60 HERTZ	1.8	534	1.7	674	1.6	783	1.5	890	1.2	1020	0.9	1200	0.5	1458
55 HERTZ	1.6	482	1.4	576	1.3	666	1.1	769	0.8	902	0.5	1083	0.0	1328
50 HERTZ	1.2	392	1.1	470	1.0	549	0.8	639	0.5	749	0.0	887		
45 HERTZ	0.9	325	0.8	394	0.6	475	0.4	568	0.1	671				

### PRESSURE DROP RATINGS FOR COILS

Pressure Drop for selected Coil (below) must be subtracted from Unit External Static Pressure (above) to determine the net available external static pressure.

COIL PRESSURE DROP (in.H <sub>2</sub> O) vs AIRFLOW (CFM)										
TYPE	ROWS	AVAILABLE MODEL NUMBER CODES	500 CFM	750 CFM	1000 CFM	1250 CFM	1500 CFM	1750 CFM	2000 CFM	
DX Single-Circuit	5	DX5, XH5	0.1	0.2	0.2	0.3	0.3	0.4	0.5	
	3	DX3, XH3	0.1	0.1	0.2	0.2	0.2	0.3	0.4	
DX Double-Circuit	4	DU4, DH4	0.1	0.2	0.2	0.3	0.3	0.4	0.5	
	3	DU3, DH3	0.1	0.1	0.2	0.2	0.2	0.3	0.4	
HEAT PUMP Single-Circuit	4	XS4	0.1	0.2	0.2	0.3	0.3	0.4	0.5	
	3	XS3	0.1	0.1	0.2	0.2	0.3	0.3	0.4	
HEAT PUMP Double-Circuit	4	XB4	0.1	0.2	0.2	0.3	0.4	0.5	0.6	
	3	XB3	0.1	0.1	0.2	0.2	0.3	0.4	0.5	
WATER	5	CW5, CH5, SC5	0.1	0.2	0.2	0.3	0.3	0.4	0.5	
	4	CW4, CH4, SC4	0.1	0.1	0.2	0.2	0.3	0.4	0.4	
	3	CW3, CH3, SC3	0.1	0.1	0.1	0.2	0.2	0.3	0.3	
	1	HW1	0.1	0.1	0.1	0.1	0.1	0.1	0.1	
WATER Reheat <sup>1</sup>	1	XH <sub>n</sub> , DH <sub>n</sub> , CH <sub>n</sub>	0.1	0.1	0.1	0.1	0.1	0.1	0.1	

1: This is the only coil that can be mounted downstream of a DX or Chilled Water coil.

EXPLANATION OF COIL CODES		
CODE	COIL TYPE	CONTROL TYPE
DX	Single-Circuit DX	Temperature controller calls for cooling.
XH	Single-Circuit DX + downstream Hot Water Coil	(1) Cooling temperature control & (1) heating temperature control.
DU	Dual-Circuit DX	Temperature controller calls for cooling.
DH	Dual-Circuit DX + downstream Hot Water Coil	(1) Cooling temperature control & (1) heating temperature control.
XS	Single-Circuit DX Heat Pump	(1) Cooling temperature control & (1) heating temperature control.
XB	Dual-Circuit DX Heat Pump	(1) Cooling temperature control & (1) heating temperature control.
CW	Chilled Water	Temperature controller calls for cooling.
CH	Chilled Water Coil + downstream Hot Water Coil	(1) Cooling temperature control & (1) reheat temperature control.
SC	Single Coil for Chilled and Hot Water	(1) Cooling temperature control & (1) heating temperature control.
HW	Hot Water	Temperature controller calls for heating.

# BOOK 2: SPECIFICATIONS

## MODES OF OPERATION

### SHUTDOWN MODE

The RD2XRT enters Shutdown Mode when:

- There is no call for ventilation
- In Shutdown Mode both blowers are turned off and the isolation dampers are closed.

### ENERGY RECOVERY MODE

The RD2XRT enters Energy Recovery Mode when:

- There is a call for ventilation
- AND outside air enthalpy is greater than return air enthalpy
- OR outside air temperature is below set point (55F factory setting)

In Energy Recovery Mode the isolation dampers are open and both blowers are turned on. The bypass dampers allow air flow through the energy exchange core only. When in Energy Recovery Mode the unit can also be in Dehumidification Mode or Heating Mode.

### ENERGY RECOVERY BYPASS MODE

The RD2XRT enters Full Bypass Mode when:

- There is a call for ventilation
- AND outside air enthalpy is less than return air enthalpy
- AND outside air temperature is above set point (55F factory setting)

In Full Bypass Mode the isolation dampers are open and both blowers are turned on. The bypass dampers divert all outside air flow entirely through the bypass and not through the energy exchange core. Return Air continues to pass through the core. When in Full Bypass Mode the unit can also be in Dehumidification Mode.

### DEHUMIDIFICATION MODE (OPTIONAL FEATURE)

The RD2XRT enters Dehumidification Mode when:

- external call for ventilation
- AND Energy Recovery Mode or Full Bypass Mode
- AND fresh air temperature is above set point (53°F factory setting)

In Dehumidification Mode the unit operates either in Energy Recovery Mode or Full Bypass Mode. A dry contact connection is provided to signal external equipment (provided by others) to deliver chilled water or refrigerant to the coil.

### HEATING MODE (OPTIONAL FEATURE)

The RD2XRT enters Heating Mode when:

- there is an external call for ventilation
- AND unit is in Energy Recovery Mode
- AND fresh air temperature is below set point (50°F factory setting)

In Heating Mode the unit operates as in Energy Recovery Mode. A dry contact connection is provided to signal external equipment (provided by others) to deliver hot water or refrigerant to the coil.

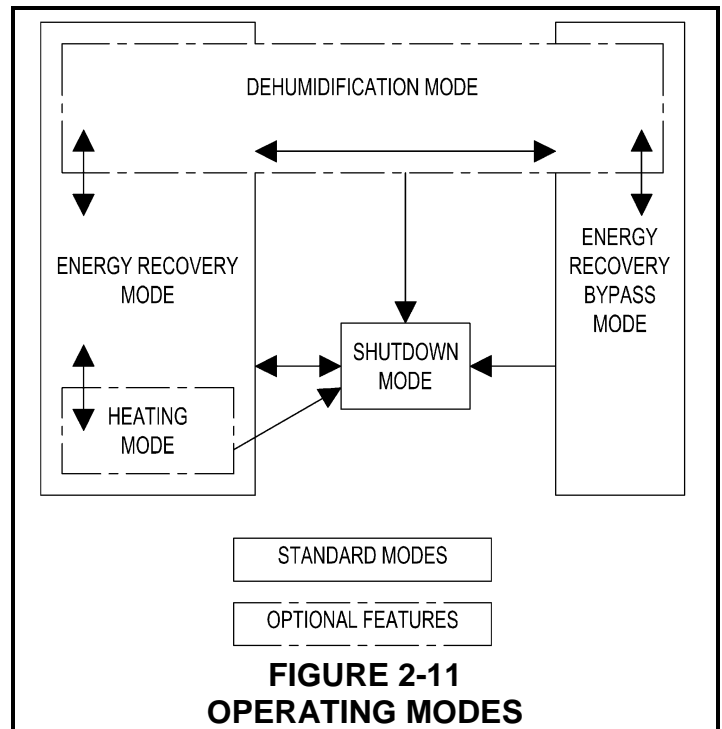

# BOOK 2: SPECIFICATIONS

## UNIT CONTROL SCENARIOS AND OPERATING SEQUENCES

### “START” AND “FREQUENCY” COMMANDS

RD2X unit operation requires two signals: a START command and a FREQUENCY command. The sources and types of these signals can vary. When the unit receives a START command the on-board relay coil is energized and power is provided to the isolation damper actuators. The isolation dampers open. When the dampers are fully open a signal is sent to the variable frequency drives (VFD) to start forward rotation of the motors. The VFDs then operate at the FREQUENCY command established for each drive. The RD2X operates in different modes depending on conditions monitored by the on-board controllers.

### PRINCIPLES OF EXTERNAL CONTROL

The RD2X can be operated by various external control devices including remote switch or relay, digital time clock with relay, occupancy sensor with relay, and carbon dioxide sensor with relay and analog output. These devices are commonly known as 2-wire, 3-wire, and 4-wire devices.

The external control devices can be connected to the RD2X to operate each blower independently or for one blower to act as leader and the other blower to act as follower. When operating independently, a single external switch or relay calls for operation but each VFD can respond independently to keypad, presets, or analog signal source.

When the VFDs are set up as leader-follower, a single external switch or relay calls for operation; then one VFD responds to keypad, presets, or analog signal. The other VFD follows the leader’s response either exactly or at an offset above or below the leader’s response. The RD2X has the versatility that either the exhaust air (EA) VFD or the fresh air (FA) VFD can act as leader.

All external control device wires are connected to the terminal block(s) in the blower module’s low-voltage electrical enclosure (see Figure 2-12, this page). Then the VFD’s are programmed by setting the “VFD Parameters” to respond correctly to the external control. The VFD’s are pre-programmed at the factory so only a few parameters need change for a specific installation.

See Book 5 for detailed information on control connections and setting VFD parameters.

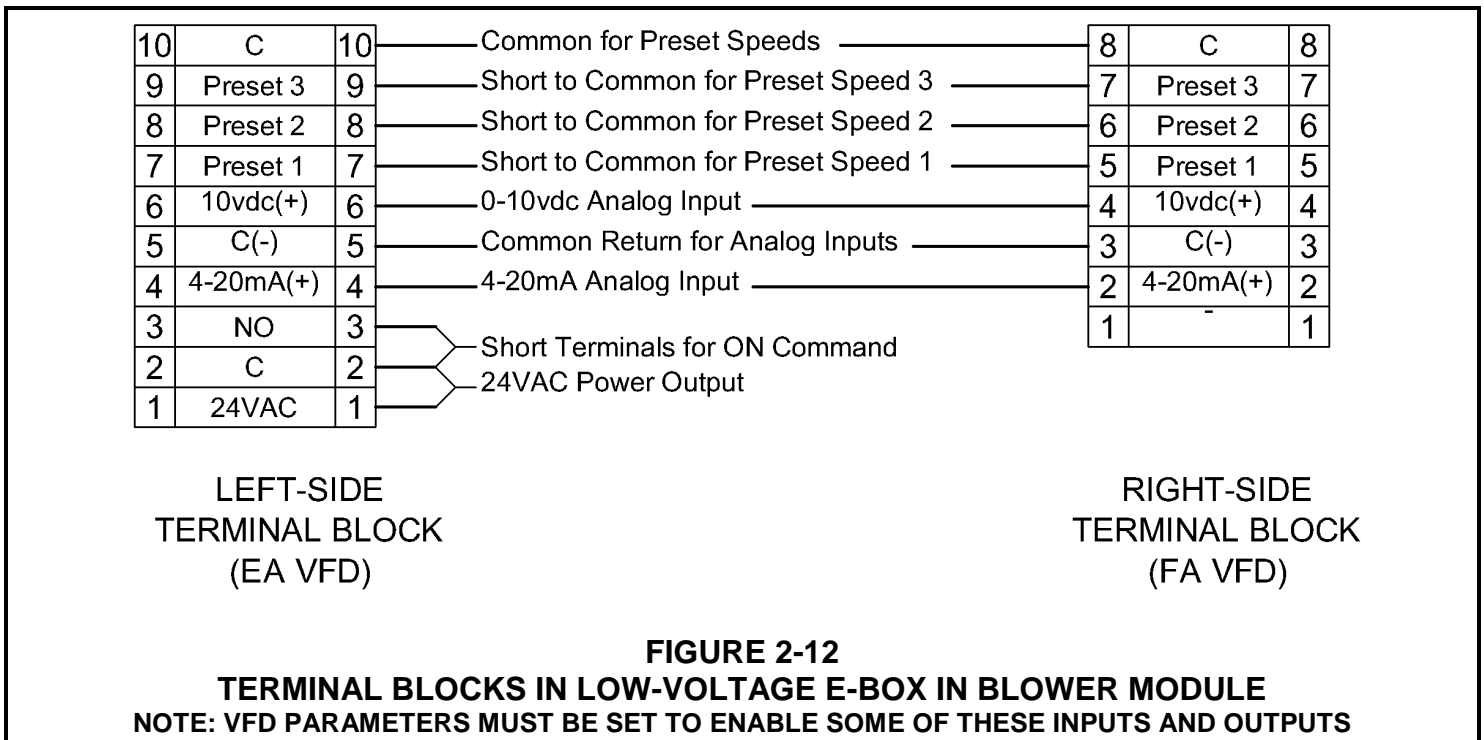

# BOOK 2: SPECIFICATIONS

## UNIT CONTROL SCENARIOS AND OPERATING SEQUENCES

### UNIT CONTROL SCENARIOS

#### 1. EXTERNAL CALL FOR VENTILATION FROM ON/OFF SWITCH OR TIME CLOCK WITH PRESET FREQUENCY SETTING.

- The unit receives an external call for ventilation from an ON/OFF type switch.
- The on-board relay coil is energized and the isolation dampers open.
- When open, the damper actuator end switch sends a signal to the VFD to start forward rotation.
- The VFD frequency command is preset at any frequency up to 60 hertz.

EXAMPLE CONTROL: RenewAire TC7D Time Clock.

#### 2. EXTERNAL CALL FOR VENTILATION FROM OCCUPANCY SENSOR (ON/OFF RELAY) WITH PRESET FREQUENCY SETTING.

- The unit receives an external call for ventilation from an Occupancy sensor ON/OFF relay.
- The on-board relay coil is energized and the isolation dampers open.
- When open, the damper actuator end switch sends a signal to the VFD to start forward rotation.
- The VFD frequency command is preset at any frequency up to 60 hertz.

EXAMPLE CONTROL: RenewAire MC-C or MC-W Occupancy Sensor.

#### 3. EXTERNAL CALL FOR VENTILATION FROM CO2 SENSOR (ON/OFF RELAY) WITH PRESET FREQUENCY SETTING.

- The unit receives an external call for ventilation from a CO2 sensor ON/OFF relay.
- The on-board relay coil is energized and the isolation dampers open.
- When open, the damper actuator end switch sends a signal to the VFD to start forward rotation.
- The VFD frequency command is preset at any frequency up to 60 hertz.

#### 4. EXTERNAL CALL FOR VENTILATION FROM CO2 SENSOR (ON/OFF RELAY) WITH PROPORTIONAL FREQUENCY SETTING (0-10VDC OR 4-20MA SIGNAL).

- The unit receives an external call for ventilation from a CO2 sensor ON/OFF relay.
- The on-board relay coil is energized and the isolation dampers open.
- When open, the damper actuator end switch sends a signal to the VFD to start forward rotation.
- The VFD frequency command is a proportional 4-20mA signal from the CO2 sensor. A 4 mA signal will result in VFD operation at the preset minimum ventilation rate. The 20 mA signal will result in VFD operation at the preset maximum ventilation rate.
- The ventilation rate will change as a linear function of the CO2 level in the space.

EXAMPLE CONTROL: RenewAire CO2-W or CO2-D Carbon Dioxide Controller.

#### 5. MINIMUM VENTILATION RATE WITH PROPORTIONAL FREQUENCY SETTING FROM CO2 SENSOR (4-20MA SIGNAL).

- The unit is always on with the isolation dampers always open to provide at least the minimum amount of ventilation at all times.
- The VFD frequency command is a proportional 4-20mA signal from the CO2 sensor. A 4 mA signal will result in VFD operation at the preset minimum ventilation rate. The 20 mA signal will result in VFD operation at the preset maximum ventilation rate.
- The ventilation rate will increase from the minimum to the maximum as a linear function of the CO2 level in the space.

EXAMPLE CONTROL: RenewAire CO2-W or CO2-D Carbon Dioxide Controller.

#### 6. EXTERNAL CALL FOR VENTILATION (ON/OFF TYPE) WITH PRESET FREQUENCY SETTINGS (LO-MED-HI).

- The unit receives an external call for ventilation from an ON/OFF type switch.
- The on-board relay coil is energized and the isolation dampers open.
- When open, the damper actuator end switch sends a signal to the VFD to start forward rotation. The VFD frequency command is preset dependent on a request for low, medium, or high speed blower operation.

# BOOK 2: SPECIFICATIONS

## CONNECTIONS TO EXTERNAL EQUIPMENT

The RD2X provides “dry contact” connections to signal external equipment supplied by others. These signals include indication of Recovery Bypass mode, Dehumidification mode, Heating mode, and Filter Alarm (dependent on options chosen).

Terminal blocks in the low-voltage compartment in the RD2X **core** segment allows for these connections. See the section on Electrical Schematics for connection of these various signals.

The “dry contact” connection is provided through a relay rated 10A at 277VAC on the temperature controller.

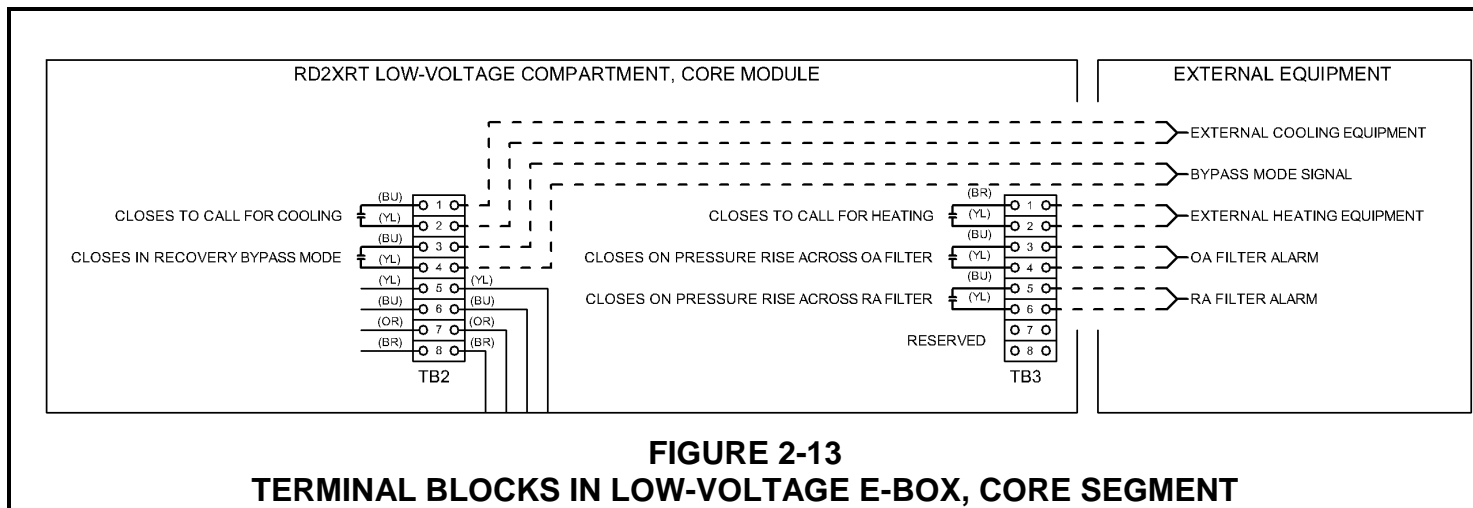



### Part I – General

#### A. Product Specification

The unit shall be a packaged static-plate energy recovery DOAS manufactured by RenewAire with heating/cooling coils and recovery bypass features.

#### B. Quality Assurance

1. The energy recovery cores used in these products shall be third party Certified by AHRI under its Standard 1060 for Energy Recovery Ventilators. AHRI published certifications shall confirm manufacturer's published performance for airflow, static pressure, temperature and total effectiveness, purge air (OACF) and exhaust air leakage (EATR). Products that are not currently AHRI Certified will not be accepted. OACF shall be no more than 1.02 and EATR shall be at 0% against balanced airflow.
2. Manufacturer shall be able to provide evidence of independent testing of the core by Underwriters Laboratory (UL), verifying a maximum flame spread index (FSI) of 25 and a maximum smoke developed index (SDI) of 50 thereby meeting NFPA 90A and NFPA 90B requirements for materials in a compartment handling air intended for circulation through a duct system. The method of test shall be UL Standard 723.
3. Unit shall be Listed under UL 1812 Standard for Ducted Air to Air Heat Exchangers and comply with CSA Standard 22.2. Some exceptions to UL Listing may apply. Units intended for "Outdoor Use" shall be listed using the specific UL requirements for rain penetration, corrosion protection and seal durability and shall be so labeled.
4. The ERV core shall be warranted to be free of manufacturing defects and to retain its functional characteristics, under circumstances of normal use, for a period of 10 years from the date of purchase. The balance-of-unit shall be warranted to be free of manufacturing defects and to retain its functional characteristics, under circumstances of normal use, for a period of 2 years from the date of purchase.

### Part II – Performance

#### A. Energy Transfer

The ERV shall be capable of transferring both sensible and latent energy between airstreams. Latent energy transfer shall be accomplished by direct water vapor transfer from one air stream to the other, without exposing transfer media in succeeding cycles directly to the exhaust air and then to the fresh air.

#### B. Passive Frost Control

The energy recovery core shall perform without the occurrence of condensation or frosting under normal operating conditions (defined as outside temperatures above -10°F and inside relative humidity below 40%). Occasional extreme conditions shall not affect the usual function or performance of the energy recovery core.

#### C. Positive Air stream Separation

Exhaust and fresh airstreams shall at all times travel in separate passages, and airstreams shall not mix. The exhaust air transfer ratio (EATR) of the energy recovery component shall be AHRI-1060 certified as 0% at balanced pressure. No metal separators or metal core material shall be acceptable.

#### D. Laminar Flow

Airflow through the energy recovery core shall be laminar, avoiding deposition of particulates on the interior of the exchange plate material.

#### E. Isolation Dampers

Isolation dampers shall be AMCA-certified Class 1 or Class 1A to demonstrate leakage of less than 4 SCFM/ft<sup>2</sup> at 1.0" H<sub>2</sub>O static pressure difference (forward flow), thus satisfying requirements of ASHRAE 90.1-2007 Section 6.4.3.4.3. Dampers shall be equipped with replaceable EPDM blade seals and stainless steel compression jamb seals. Dampers shall be controlled to be fully open before blowers begin operation, and to be fully closed whenever ventilation is not called for.

#### F. Energy Recovery Bypass

Energy recovery shall be bypassed by means of a face-and-bypass damper located in the Outside Air stream. Bypass section of damper shall be AMCA-certified Class 1 or Class 1A to demonstrate leakage of less than 4 SCFM/ft<sup>2</sup> at 1.0" H<sub>2</sub>O static pressure difference (forward flow). Both sections of damper shall be equipped with replaceable EPDM blade seals and stainless steel compression jamb seals. Damper shall be controlled by a differential enthalpy controller and an adjustable low-limit control.

### Part III – Product

#### A. Construction

1. The energy recovery core shall be of static plate, cross-flow construction, with no moving parts.
2. The unit cabinet shall be constructed of galvanized, 20-gauge steel, with lapped corners and zinc-plated screw fasteners. The unit roof shall have watertight standing seam joints and shall overlap wall panels and doors to positively shed water.
3. All unit cabinet panels shall be insulated to a minimum R-value of 4.3 (hr·ft<sup>2</sup>·°F/BTU).
4. (Single-wall units) All compartments shall be fully lined with Foil-Scrim facing. Energy Recovery Bypass plenum, coil plenum and Fresh Air Blower plenum shall be additionally lined with 24-gauge minimum G90 galvanized steel.  
(Double-wall units) All compartments shall be fully lined with 24-gauge minimum G90 galvanized steel.
5. All unit cabinet panels shall display deflection no greater than L/240 for RD2X and L/120 for RD4X when unit is depressurized to -2.0" relative to ambient.
6. Unit shall be provided on a 12 gauge base rail for RD2X or 10-gauge base rail for RD4X with provisions for movement on site by fork.
7. Unit shall be provided with (4) lifting points suitable for placement of the unit on a roof curb by crane or other lifting means. Rigging information including weights at lifting points and spreader bar requirements shall be provided.
8. Flange components shall be provided suitable for connection of ductwork.
9. Weather hoods shall be screened to exclude birds and animals. Inlet weather hoods shall be equipped with rain excluded baffles.
10. The exhaust and fresh air streams shall both be protected by MERV 8 rated, 2 inch pleated, disposable filters (MERV 13 optional) positioned before the energy recovery core.
11. The unit shall have single-point power connection.
12. Motors shall be NEMA-Premium efficiency, Totally Enclosed Fan-Cooled (TEFC), with inverter-rated construction.
13. Motors shall be controlled by individual Variable Frequency Drives, each of which shall be additionally protected by fuses contained in the unit electrical enclosure.
14. The keypads of the Variable Frequency Drives shall be accessible by means of removable access panels while the unit is running, without exposure of internal wiring or connections. Air leakage through the access panels while open shall not exceed 60SCFM under any operating conditions.
15. Unit compartments containing high voltage shall be accessible through a door which cannot be opened until the unit's primary load switch is turned off to disconnect all power downstream of that switch.
16. Static pressure measurement ports shall be provided along with charts such that both airflows across the energy recovery core can be measured during unit operation, in energy recovery or bypass modes, with an uncertainty less than 10%.
17. Internal operating logic shall be provided by stand-alone relays, temperature controllers, and enthalpy controllers.
18. The unit electrical box shall include a factory installed, non-fused disconnect switch and a 24 VAC, Class II transformer/relay package.
19. Blower type shall be quiet running direct drive and forward curved.
20. Blowers shall be premium efficiency, EISA compliant for energy recovery efficiency. The blower motors shall be totally enclosed (TEFC) and shall be supplied with factory installed VFDs.



