

RD2XRT INSTALLATION AND OPERATION MANUAL

BOOK 3

MECHANICAL

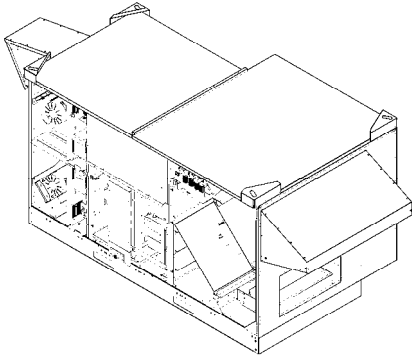

ABOUT BOOK 3:

This book covers the mechanical installation of the RD2XRT.

See Book 1 for an overview of the RD2X and system design considerations.

See Book 2 for product and performance specifications.

See Book 4 for basic electrical connections and wiring schematics.

See Book 5 for control system connections, VFD adjustment, Start-Up, Commissioning or Maintenance.

This book does not cover overall system design or system integration issues. Some of these issues are discussed in Books 1 and 5, but in general, specification documents provided by a qualified specifying engineer are to be considered the Basis of System Design.

Following these instructions does not necessarily assure compliance with local codes and standards, which must always be observed.

UNPACKING INSPECTION

Move the RD2X to its staging location and remove packaging. Inspect the unit for visual signs of damage.

Table of Contents

BOOK 1: Overview	
Product Features	2
De-Coupled and DOAS System Overview	3
RD2X Psychrometrics	4
System Integration	6
Critical Warnings	7
Checklist for Specifying Engineer	8
BOOK 2: Specifications	
Product Features	2
Available Features	3
Descriptive Drawings	4
Configuration Codes	6
Condensed Specifications	8
Dimensions	10
Ratings	12
Modes of Operation	19
Unit Controls and Operating Sequences	20
Connections to External Equipment	22
Guide Specifications	23
BOOK 3: Mechanical Installation	
Product Features	2
Order of Installation	3
Critical Dimensions	4
Curb and Rail Dimensions	5
Service Clearances	6
Curb and Rail Installation Considerations	7
Rigging Information	8
Securing the Unit Against Wind Loads	9
Ducting	10
Coil and Drain Connections	11
How to Reconfigure the Inlet and Outlet (opt.)	12
How to Install Field-Supplied Coil (opt.)	14
BOOK 4: Electrical Installation	
Product Features	2
Power Connections	3
Disconnect Switch Ratings	5
On-Board Transformer	6
Control Connections	7
Electrical Installation Checklists	8
Schematics	10
Ladder Schematics	18
BOOK 5: Start-Up, Commissioning and Maintenance	
Initial Checks	3
Balance Air Flow	4
Review / Adjust On-Board Controls (opt.)	6
VFD Parameters	8
Control Connection Examples: On/Off and 3-speed	11
Analog Control of the VFDs -- General	16
Scaling to VFD Response to Analog Inputs	17
Control Connection Examples: Analog Controllers	22
Control Connection Examples: Mixed Analog & On/Off/35	22
To Reset VFD Parameters	39
Service Parts	40
Warranty Information	48
Records	49

BOOK 3: MECHANICAL

PRODUCT FEATURES

The RD2X is an Energy Recovery Ventilator with available features designed for Dedicated Outdoor Air Systems.

Standard features include:

- Energy recovery by fixed-plate enthalpic energy exchanger
- Enthalpy- and temperature-controlled bypass of energy recovery
- Isolation dampers that shut down when ventilation is not needed
- Variable-Frequency Drive (VFD)-controlled direct-drive fresh air and exhaust air blowers
- Integrated disconnect switch
- Airflow measurement stations

Available features include:

- Heating and/or cooling coils for post-treatment of fresh air
- Double-wall construction

PRINCIPLE OF OPERATION

The RD2X can operate in up to four modes depending on options installed:

- Energy Recovery mode: the unit transfers heating or cooling energy from the exhaust air to the fresh air.
- Recovery Bypass mode: the unit takes advantage of free cooling from the outside air and doesn't transfer energy between air streams.
- Dehumidification mode: the unit conditions the fresh air to 53°F.
- Heating mode: the unit tempers the fresh air to 75°F.

The RD2X operates automatically. The unit receives an external call for ventilation. Its isolation dampers open and turn on the variable frequency drives and blowers. The unit determines the operating mode by continuously monitoring the air streams for temperature and enthalpy.

The RD2X does not include a condensing unit, chiller, heat pump or boiler. When a coil for dehumidification or cooling is part of the RD2X unit, the condensing unit, chiller, heat pump or boiler is separately installed to meet the needs of the complete system. RD2X units equipped with coils include connection points to call for operation of the separate heating or cooling equipment.

However, no fluid or refrigerant flow control valve (TX valve) is provided, and must be specified by the designer of the overall system for separate sourcing.

OPERATING CONTROLS

A wide variety of low voltage (24VAC) control schemes may be selected to meet the ventilation needs of the facility. These may include time clock, occupancy sensor, carbon dioxide sensor, and others. DDC systems may also control the unit with external control by other. **TX valves are not provided.**

WARNING

RISK OF FIRE, ELECTRIC SHOCK, OR INJURY.

OBSERVE ALL CODES AND THE FOLLOWING:

1. Before servicing or cleaning the unit, switch power off at disconnect switch or service panel and lock-out/tag-out to prevent power from being switched on accidentally. More than one disconnect switch may be required to de-energize the equipment for servicing.
2. This installation manual shows the suggested installation method. Additional measures may be required by local codes and standards.
3. Installation work and electrical wiring must be done by qualified professional(s) in accordance with all applicable codes, standards and licensing requirements.
4. Any structural alterations necessary for installation must comply with all applicable building, health, and safety code requirements.
5. This unit must be grounded.
6. Sufficient air is needed for proper combustion and exhausting of gases through the flue (chimney) of fuel burning equipment that might be installed in the area affected by this equipment. If this unit is exhausting air from a space in which chimney-vented fuel burning equipment is located, take steps to assure that combustion air supply is not affected. Follow the heating equipment manufacturer's requirements and the combustion air supply requirements of applicable codes and standards.
7. Use the unit only in the manner intended by the manufacturer. If you have questions, contact the manufacturer.
8. This unit is intended for general ventilating only. Do not use to exhaust hazardous or explosive materials and vapors. Do not connect this unit to range hoods, fume hoods or collection systems for toxics.
9. When cutting or drilling into wall or ceiling, do not damage electrical wiring and other hidden utilities.
10. If installed indoors this unit must be properly ducted to the outdoors.

CAUTION

To avoid motor bearing damage and noisy and/or unbalanced impellers, keep drywall spray, construction dust etc, out of unit.

BOOK 3: MECHANICAL

ORDER OF INSTALLATION

ESSENTIAL STEPS – CURB MOUNT

PLAN THE INSTALLATION	this page
INSTALL CURB	page 7
INSTALL DUCTS	page 11
RECONFIGURE THE UNIT (if necessary)	page 12
MOVE THE UNIT TO THE CURB	this page
SECURE THE UNIT TO THE CURB	page 7, 9
CONNECT COILS TO HEATING/COOLING EQUIPMENT (if necessary)	page 11
CONNECT POWER AND CONTROLS TO UNIT	BOOK 4

ESSENTIAL STEPS – RAIL OR PLATFORM MOUNT

PLAN THE INSTALLATION	this page
INSTALL RAILS OR PLATFORM	page 7
RECONFIGURE THE UNIT (if necessary)	page 12
MOVE THE UNIT TO THE RAILS OR PLATFORM	this page
SECURE THE UNIT TO THE RAILS OR PLATFORM	page 7, 9
INSTALL DUCTS	page 11
CONNECT COILS TO HEATING/COOLING EQUIPMENT (if necessary)	page 11
CONNECT POWER AND CONTROLS TO UNIT	BOOK 4

PLAN THE INSTALLATION

Plan the installation before starting:

- Determine how the unit will be moved to its installation location, and whether available equipment can handle the unit. See “RIGGING INFORMATION”.
- Insure there will be access to the front and rear of the unit for maintenance and service. See “SERVICE CLEARANCES”.
- Visualize the ducting layout. If the inlet and outlet connections on the unit need to be re-configured do this prior to installation. See “FIELD RE-CONFIGURATION OF INLET AND OUTLET”.
- Know where the line voltage and control wires are connected. See “CRITICAL DIMENSIONS”.
- Confirm routing of pipes connected to coils (if applicable) including the condensate drain line.

MOVE THE UNIT

The RD2XRT is designed for installation outside, on a roof curb or mounting rails. The unit must be on a level surface or slightly pitched from back to front of the unit to allow for proper drainage of the condensate drain pan out the front of the unit. See “SECURING AGAINST WIND LOADS” AND “DUCTING” for additional information about proper installation locations.

See next page for illustrations of critical dimensions and weights for moving the unit, and for final location of the unit.

CAUTION

Do not stand on the unit. Do not stack or store items on the unit when installed.

BOOK 3: MECHANICAL

CRITICAL DIMENSIONS

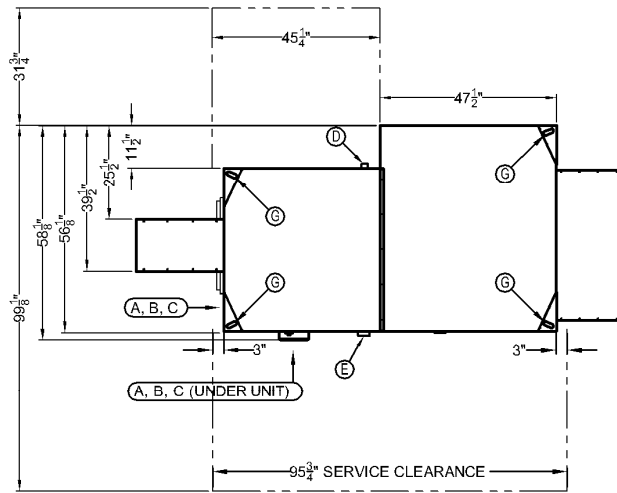

KEY TO AIRFLOW CODES	
OA	OUTSIDE AIR INTO UNIT
RA	ROOM AIR INTO UNIT
FA	FRESH AIR FROM UNIT
EA	EXHAUST AIR FROM UNIT

KEY TO CALL-OUTS	
A	POWER CONNECTION 7/8Ø
B	UNIT LOW-VOLTAGE CONTROL CONNECTIONS (2) 1/8Ø
C	EXTERNAL EQUIPMENT LOW-VOLTAGE CONTROL CONNECTION 1/4Ø
D	COIL CONNECTIONS - SIZE AND LOCATION VARY
E	CONDENSATE DRAIN
F	VFD ACCESS COVER
G	LIFTING POINTS (4)

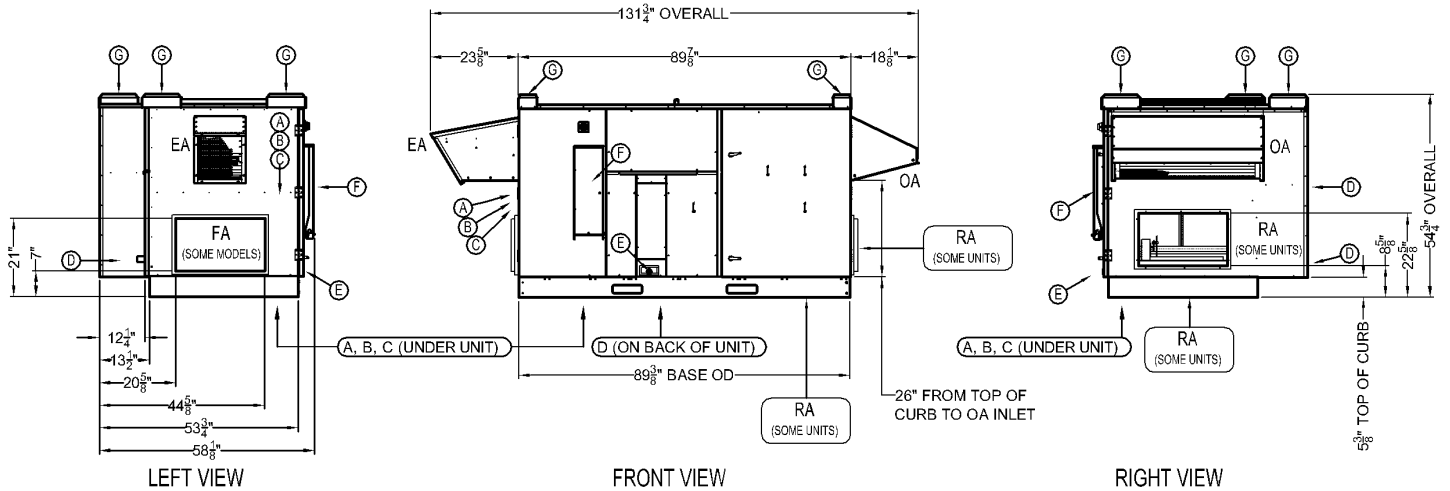
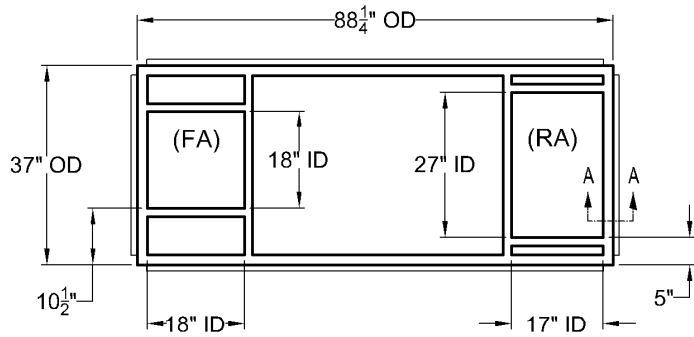

FIGURE 3-1
CRITICAL DIMENSIONS

SHIPPING WEIGHT ON PALLET APPROXIMATELY 1280 LBS.

BOOK 3: MECHANICAL

CURB AND RAIL DIMENSIONS



PLAN VIEW - STANDARD CURB

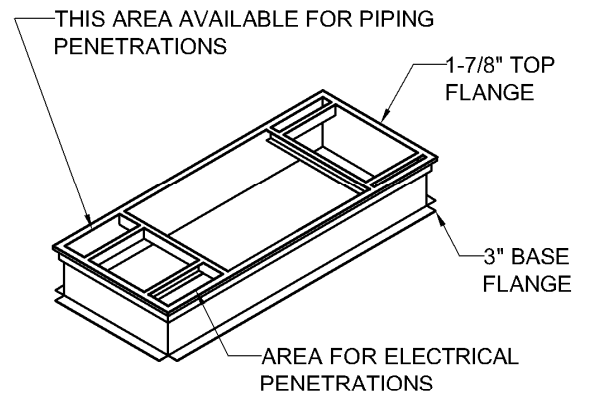

ISOMETRIC VIEW - STANDARD CURB



SIDE VIEW - STANDARD CURB

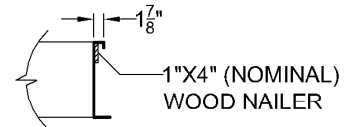

SECTION A-A

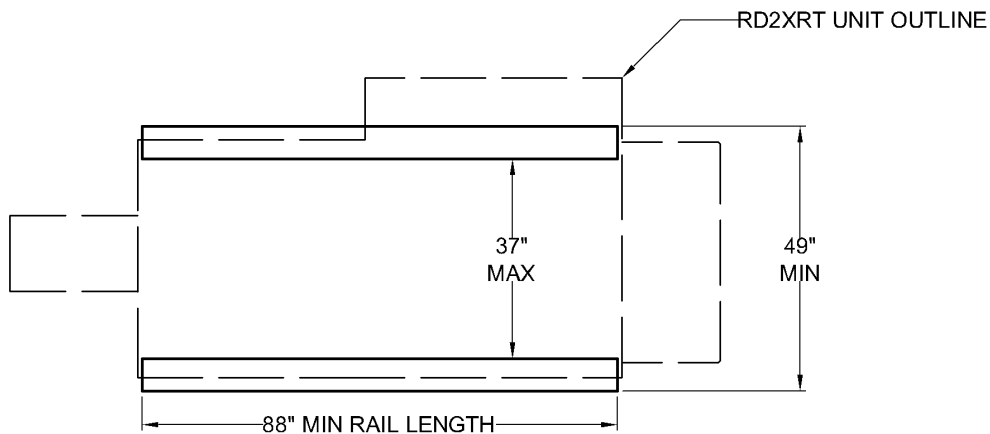

PLAN VIEW - EQUIPMENT RAIL DIMENSIONS

FIGURE 3-2
CURB AND RAIL DIMENSIONS

BOOK 3: MECHANICAL

SERVICE CLEARANCES

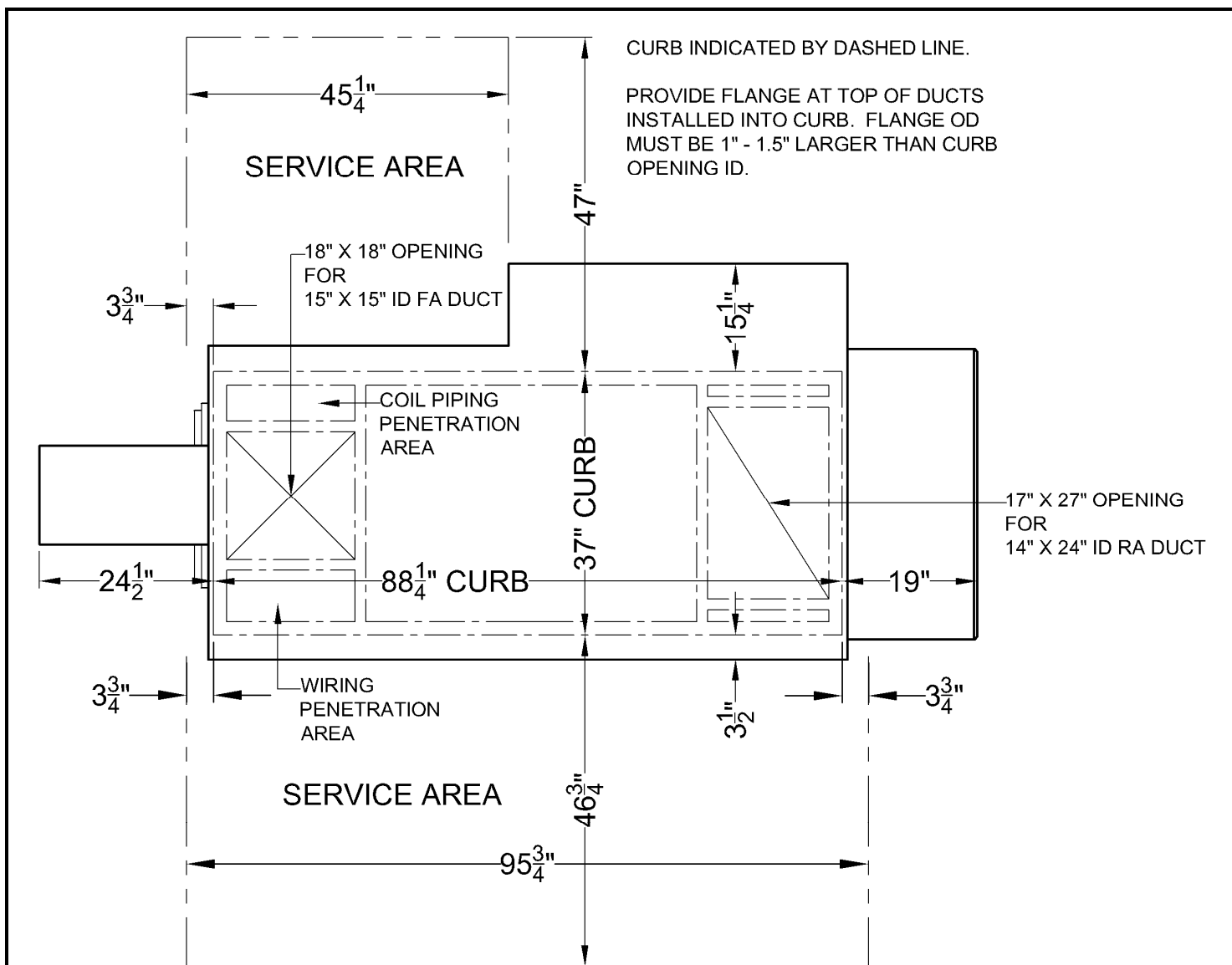

FIGURE 3-3
SERVICE CLEARANCES FROM CURB OR RAILS

INSTALLED UNIT WEIGHT: 1158 LBS (varies slightly with installed options)

For installed corner weights, see Book 2 Fig. 2-19.

For weights at lifting lugs, see this book's Fig 3-4 RIGGING INFORMATION.

BOOK 3: MECHANICAL

CURB/RAIL INSTALLATION CONSIDERATIONS

CURB OR EQUIPMENT RAILS?

Curbs must be used if either the Fresh Air outlet or the Return Air inlet is located in the base of the unit.

Equipment Rails may be used if both the Fresh Air outlet and the Return Air inlet are located in the sides of the unit.

See Figure 3-2, page 5, for recommended Curb or Equipment Rail dimensions.

CURB/RAIL HEIGHT

We recommend a minimum 14" curb or rail height from the structural roof. However, consider local codes and practice with respect to snow buildup. See Figure 3-1 for distance from top of curb/rail to the OA inlet.

CURB/RAIL LOCATION

The RD unit must be located so that the OA inlet is at least 10' from any building air exhaust, sanitary vent piping, fume hood exhausts, or combustion product exhausts. Local codes must also be observed.

Curb or rail must be located so that the building structure can support it. Consider both static loads of the equipment, seismic loads, and wind loads.

Confirm that the curb/rail location allows for proper connection of the ducts, electrical power and control wires, coil and condensate pipes, and provides necessary service access. See Figure 3-1, page 4 and Figure 3-3, page 6.

ATTACH CURB OR RAIL TO BUILDING TO RESIST WIND AND SEISMIC LOADS

Since the curb or rails attach the unit to the building structure, they must themselves be attached to the building sufficiently well to transfer wind and seismic loads, which can be lateral, upward, and downward.

CURB OR RAIL MUST BE LEVEL

The unit must be on a level surface or slightly pitched from back to front of the unit to allow for proper drainage of the condensate drain pan out the front of the unit.

CURBS MUST BE INSULATED

Prior to installing the unit, the sides of the curb must be insulated per the manufacturer's instructions or as per standard practice. The curb or rails must also have roofing and counter-flashing applied as per standard practice.

DUCTS ARE INSTALLED IN CURB PRIOR TO UNIT INSTALLATION

Ducts which are to connect to the bottom of the RD unit must be installed into the Curb and through the roof itself before the RD unit is placed on the curb.

Do not cut out the entire area of the roof enclosed by the curb. Openings in the roof for ductwork, electrical and power and control wiring, and refrigerant or water piping, should be as small as practical, so that they may be sealed against air leakage after installation.

GASKET TAPE PROVIDED WITH CURB MUST BE INSTALLED

Gasket tape is required between the RD unit and a Curb. The gasket tape should be installed:

- at the entire perimeter of the curb;
- on the top surface of the flanges of the ducts installed in the curb.

WARNING

DO NOT SUSPEND OR HANG THE UNIT (except as shown on next page as needed to move the unit to its installation location). The RD2XRT unit is designed for installation only on curbs or equipment rails. Secure the unit to meet applicable wind and seismic load requirements per applicable codes.

WARNING

The RD2XRT should be moved by qualified personnel only. Failure to do so can result in death or serious injury.

BOOK 3: MECHANICAL

RIGGING INFORMATION

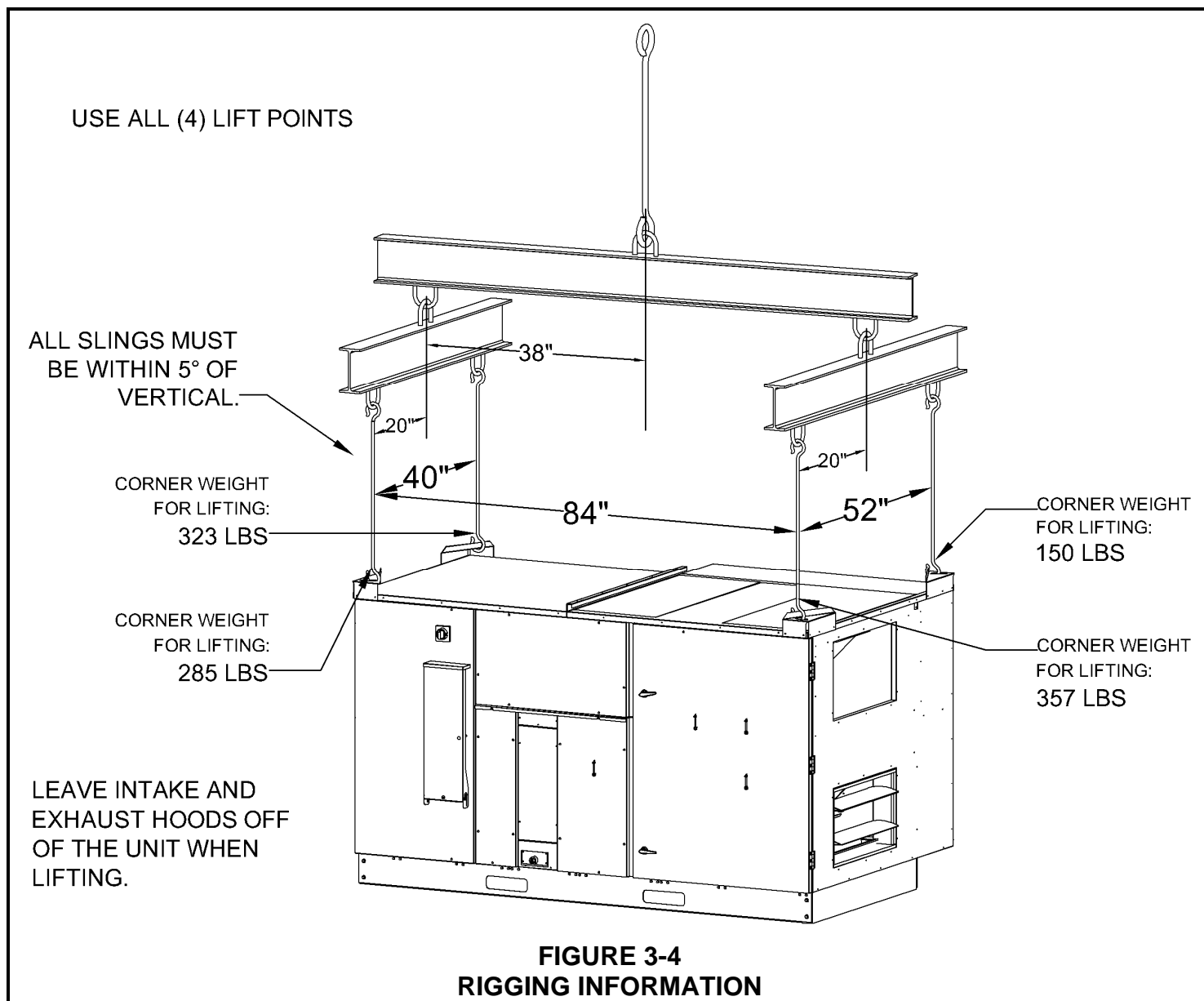

**Unit weight: 1110 LBS without hoods
(varies slightly with options installed)**

WARNING

Danger of roof damage or severe injury if high winds move this unit. Secure unit to structure. Observe local code requirements.

RenewAire strongly recommends that you secure rooftop units properly to the curb or equipment rails, and thus to the building structure. Strong winds, tornados, and hurricanes can and do displace or remove rooftop

equipment from rails or curbs. When this happens, the equipment, adjacent roof structure, and even vehicles parked near the building can be damaged, and rain typically enters the building. The equipment is put out of service and the collateral damage can be very expensive.

At a minimum, observe locally applicable codes, but note that even if local codes require some attachment means that may not be enough to withstand common wind occurrences.

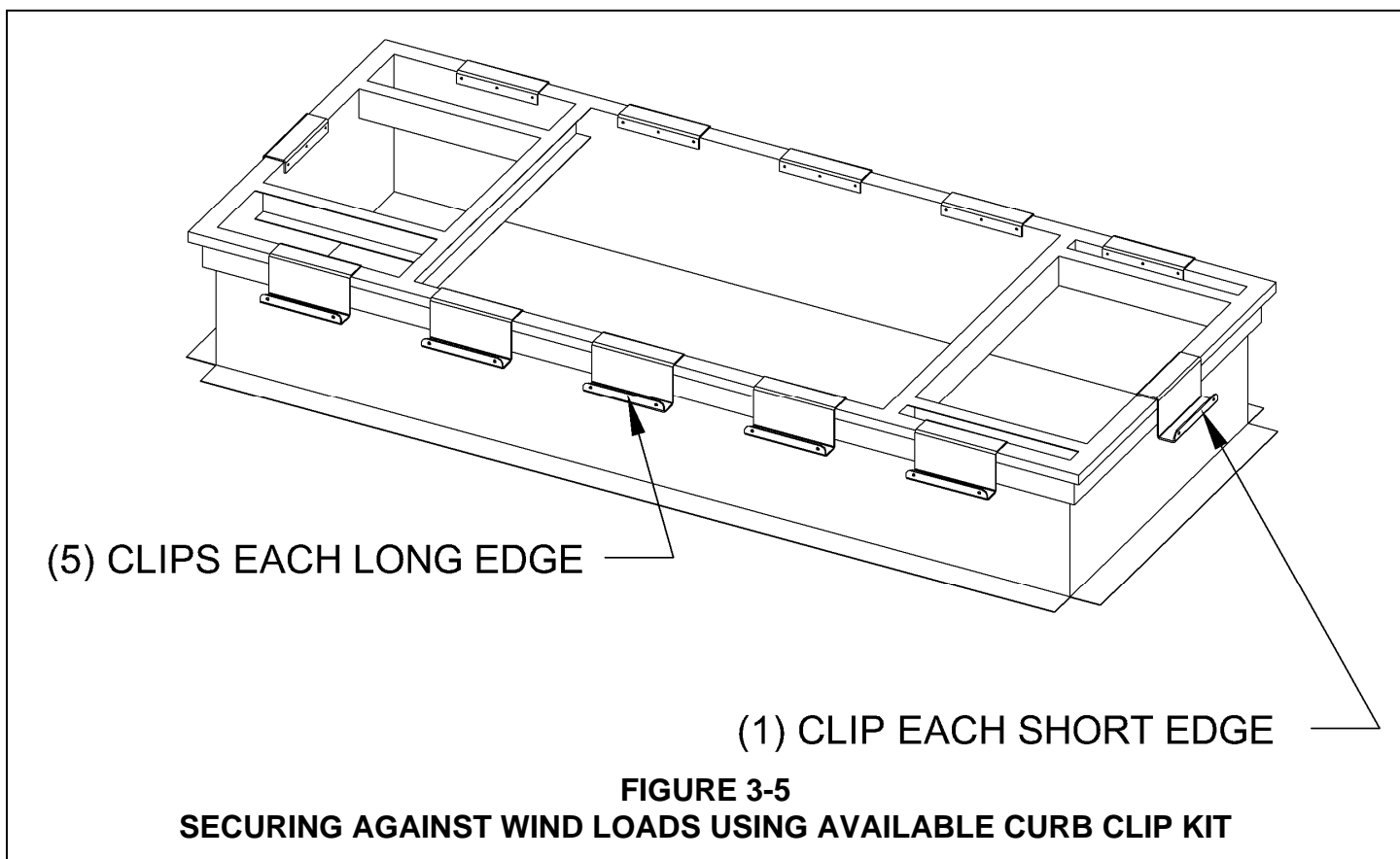

AVAILABLE CURB CLIP KIT

Shown above is one option for securing the RD2XRT unit against winds up to 90MPH. The available 2XRDC Curb Clip Kit includes clips and hardware. Clips must be installed as shown before the RD2XRT unit is placed on the curb, using supplied hardware.

The curb itself also must be properly secured to the roof decking. Further information is available in the [Curb Clips Installation Manual](#).

BOOK 3: MECHANICAL

DUCTING

DUCT CONSTRUCTION

GENERAL:

- Follow SMACNA guidelines for duct construction and airtightness.
- Follow duct design specified in construction documents in order to achieve design system airflows.

DUCTS CARRYING AIR AT DIFFERENT TEMPERATURE THAN SURROUNDINGS:

If any ducts connected to the RD unit pass through unconditioned spaces, they must be insulated, with a sealed vapor barrier on both inside and outside of the insulation.



CAUTION

Danger of condensation and resultant equipment damage or biological growth if ducts are not properly installed, sealed and insulated. Observe guidelines above as well as all applicable codes.

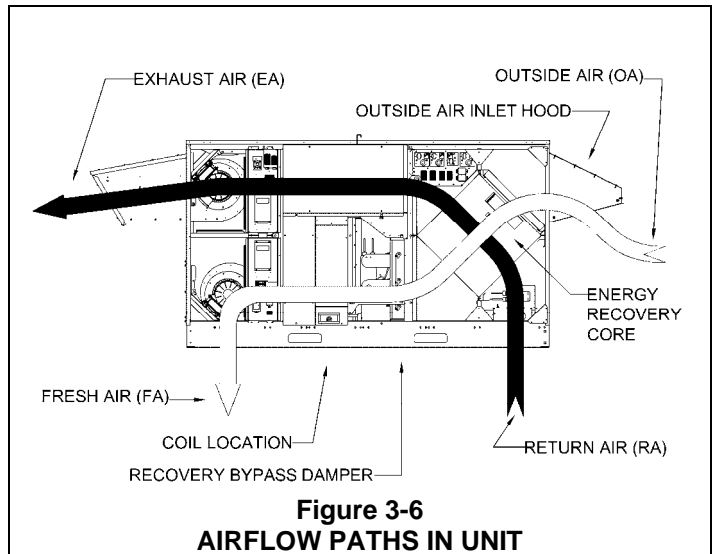

Figure 3-6
AIRFLOW PATHS IN UNIT

DESCRIPTION OF AIRFLOWS

Outside Air (OA) pass through the Outside Air Inlet Hood, entering the top right hand compartment of the unit. It passes through the energy exchange core or the bypass passage. The **Fresh Air (FA)** then flows through the coil, if present, and exits the blower and unit at the bottom left hand compartment. The **Return Air (RA)** inside the building enters the bottom right hand compartment of the unit and flows through the energy exchange core. The **Exhaust Air (EA)** then exits the blower and unit at the top left hand compartment. See Figure 3-6.

LOCATE THE UNIT FOR GOOD AIR QUALITY

Locate the unit where un-contaminated air is available. The exhaust outlet should not dump air into an enclosed space or any other structure, nor onto a walkway.



WARNING

The fresh air inlet should be at least 10' away from any exhaust, such as dryer vents, chimneys, furnace and water heater exhausts, or other sources of contamination or carbon monoxide. Do not locate the fresh air inlet where vehicles may be serviced or left idling. Never locate the fresh air inlet inside a structure.

BOOK 3: MECHANICAL

COIL AND DRAIN CONNECTIONS

When dehumidification or heating coils are part of the RD2X unit, the coils must be connected to separate equipment external to the unit. All connecting lines should be supported independently of the unit. Do not rely on the connection to the coil to support the pipes.

DIRECT EXPANSION COIL

The liquid (supply) line should be connected to the middle connection on the leaving air side for counter-flow operation

The suction line should be connected to the lower connection on the entering air side for counter-flow operation. The suction header is equipped with an external equalizer connection.

CHILLED WATER COIL

Connections for the chilled water (CW) coil include supply line and return line. Both connections are soldered copper. The supply line should be connected to the lower connection on the leaving air side for counter flow operation. The coils will vent and drain through the factory-installed vent and drain fittings when mounted level for horizontal flow.

HOT WATER COIL

Both connections are soldered copper.

CONDENSATE DRAIN

The unit's condensate drain pan is removable for easy cleaning. Keep this in mind when connecting the drain line and trap. The drain line will need to be removed from the drain pan when it is necessary to remove the drain pan for cleaning.

The drain pan has a 3/4" NPT internal threaded connection to allow for drainage of condensation off the coil. The inside of the unit is under negative pressure when operating. A trap needs to be installed to prevent air leakage into the unit during operation. Minimum requirements for condensate drain trap are shown below.

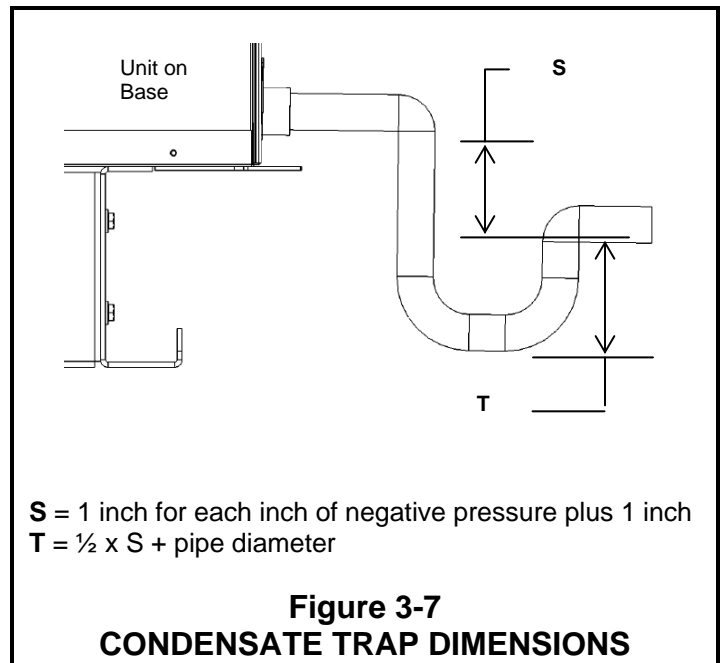

WARNING

Installation work and piping must be done by qualified professional(s) in accordance with all applicable codes, standards, and licensing requirements. Piping should be supported independently.

BOOK 3: MECHANICAL

HOW TO RECONFIGURE THE INLET AND OUTLET (OPTIONAL)

The RD2X is delivered with the inlets and outlets configured as ordered. In the event you need to reconfigure the inlet and/or outlet the RD2X provides that versatility. Follow the steps below.

TO RECONFIGURE RA INLET

1. Remove the filters and cores from the unit so they are not damaged during reconfiguration.
2. Remove the patch panel from the desired opening. Save the patch panel and associated hardware.
3. Loosen the isolation damper from the opening by removing six screws. Save the associated hardware. If the damper is located in the floor remove the brackets from the damper. They are not needed when the damper is re-located to the side wall.
4. Remove the duct flange from the side opening, if present.
5. Re-locate the isolation damper into the desired opening. It will have to be rotated 180° so the actuator does not interfere with the filters.
6. Attach the damper with the six screws. Brackets need to be fabricated if the damper is re-locating from the side wall to the floor.
7. Place the patch panel in the unused opening and attach with the saved hardware.
8. When using the side opening place the duct flange around the opening and attach with screws.
9. Caulk around the perimeter of the duct flange to provide an air tight seal.
10. Replace the cores and filters.

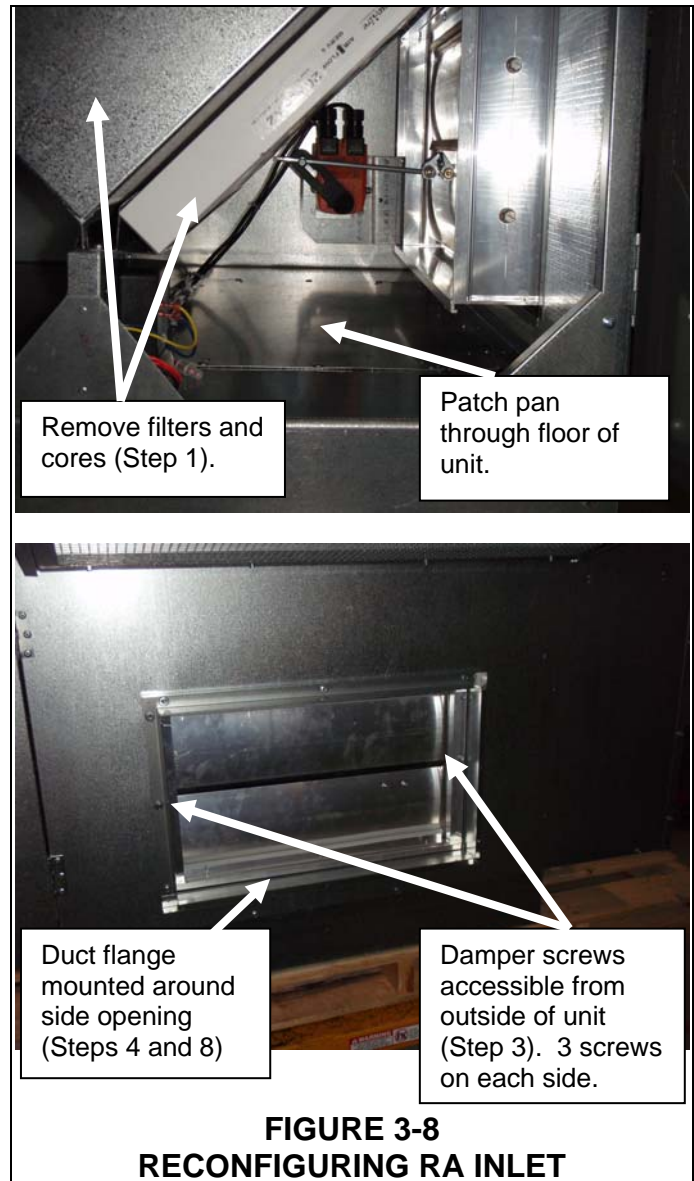

BOOK 3: MECHANICAL

HOW TO RECONFIGURE THE INLET AND OUTLET (OPTIONAL)

TO RECONFIGURE FA OUTLET

1. Remove the duct flange from the side opening, if present.
2. Remove the patch panel from the desired opening. Save the patch panel and associated hardware.
3. Loosen the bolts attaching the blower to the base plate.
4. Rotate the blower 90° to the desired outlet orientation.
5. Loosen the four bolts attaching the rail to the base plate.
6. Slide the motor assembly over to the other side of the base plate and reattach the rail to the base plate with four bolts.
7. Attach the blower to the base plate with bolts.
8. Place the patch panel in the unused opening and attach with the saved hardware.
9. When using the side opening place the duct flange around the opening and attach with screws.
10. Caulk around the perimeter of the duct flange to provide an air tight seal.

⚠ CAUTION

Motor is heavy. Do not drop. Personal injury or damage to the equipment can occur.

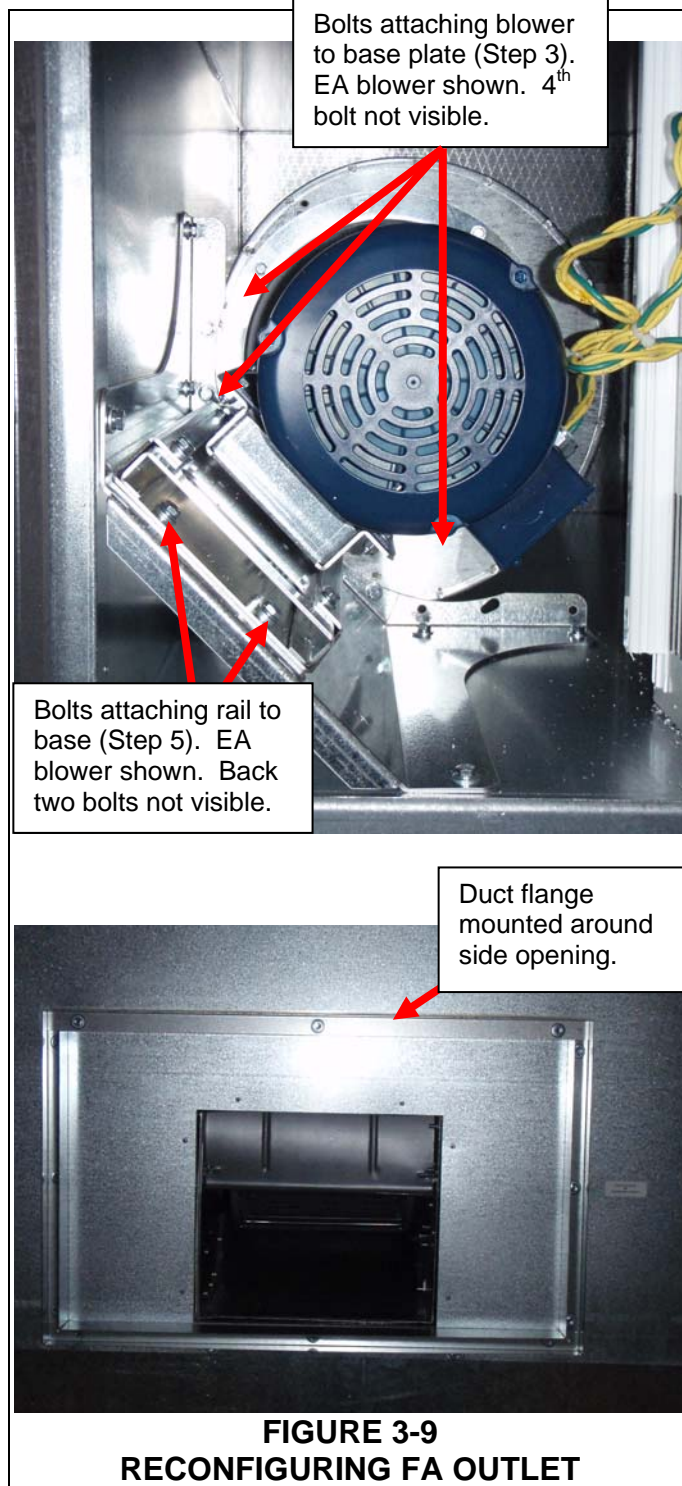

BOOK 3: MECHANICAL

HOW TO INSTALL FIELD-SUPPLIED COIL (opt.)

The RD2X can be ordered without a coil for field installation of a coil provided by others. The coil compartment is designed to accommodate a right hand air flow coil(s). Mounting brackets, drain pans and mounting bolts are provided with the unit for field installed coils.

CRITICAL COIL DIMENSIONS:

Coil including frame and headers may not exceed 37-3/4" width, 24-1/2" height.

Coil frame must be 8" in depth. If two coils are being installed in series they must be bolted together and must have a total depth of 8".

Coil Flange width must be at least 1".

Coil connections should extend so connections may be made inside the unit. Distributors and distribution lines should be kept within the volume of the maximum dimensions indicated above. See Figure 3-10, page 15.

Mounting holes must be provided in the coil frame. Installation steps below assume these holes are placed by the installing contractor.

INSTALLATION STEPS:

1. Remove the center drain pan – slide it out from the front of the coil section.
2. Remove the panels and pans from the front and back of the coil section to expose the coil area.
3. The side drain pans inside the unit do not need to be removed.
4. Drill (16) 3/8" diameter holes in the coil flanges on the air entering side of the coil (Figure 3-10, "VIEW FROM UPSTREAM").
5. Drill (5) 3/8" diameter holes in the top coil flange on the air leaving side of the coil (Figure 3-10, "VIEW FROM DOWNSTREAM").
6. Install (21) 1/4"-20 Tinnerman nuts (provided) on the coil flanges.
7. Calculate the distance between the bottom of the coil and the floor of the coil module when the coil will be installed. Place a wooden board or other like material on the floor of the module to support the coil in place when installing it.
8. Gently slide the coil between the opening of the front of the coil module and into position. Be careful not to damage the drain pans.
9. Attach the coil brackets to the coil flanges with (21) 1/4"-20 x 3/4" bolts and lock washers (provided).
10. Remove the wooden board from under the coil.
11. Drill holes in the back pans as needed for the inlet and outlet connections.
12. Install the front and back pans. Make the holes around the connections air tight.

BOOK 3: MECHANICAL

HOW TO INSTALL FIELD-SUPPLIED COIL (opt.)

VIEW FROM UPSTREAM:
COIL UPSTREAM MOUNTING PLATE,
SHOWING AVAILABLE COIL FACE AREA
AND MAXIMUM OVERALL COIL SIZE.

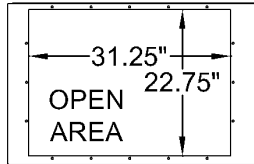

VIEW FROM UPSTREAM:
MAXIMUM THAT COIL CAN EXTEND BEYOND
REQUIRED MOUNTING HOLES

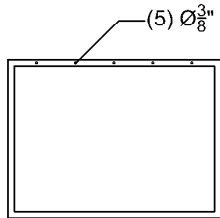
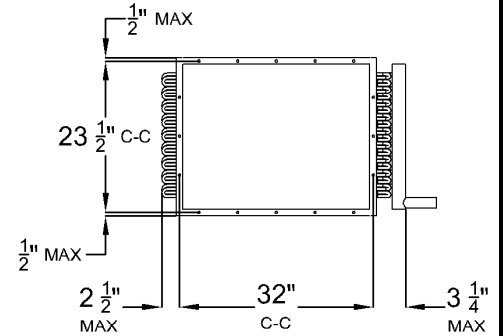

VIEW FROM DOWNSTREAM:
REQUIRED MOUNTING HOLES
IN COIL'S DOWNSTREAM FRAME.
(5) $\frac{3}{8}$ " \varnothing HOLES AS SHOWN IN TOP
FLANGE ONLY. THESE HOLES ARE IN-LINE
WITH HOLES IN UPSTREAM FRAME.

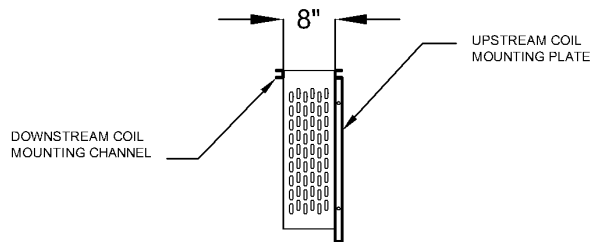

VIEW FROM FRONT OF UNIT:
DEPTH OF COIL FRAME MUST BE 8".

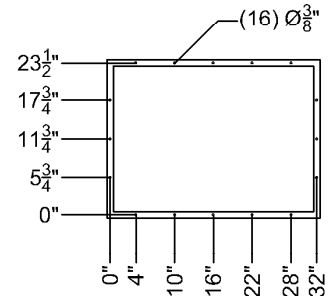

VIEW FROM UPSTREAM:
REQUIRED MOUNTING HOLES
IN COIL'S UPSTREAM FRAME.
(16) $\frac{3}{8}$ " \varnothing HOLES AS SHOWN.

Figure 3-10
CRITICAL DIMENSIONAL REQUIREMENTS FOR FIELD-SUPPLIED COIL(S)

