

RD4XRT INSTALLATION AND OPERATION MANUAL

BOOK 4

ELECTRICAL

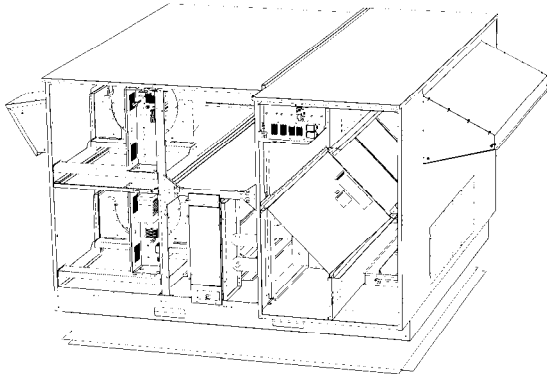

ABOUT BOOK 4:

This book covers the basic electrical installation of the RD4XRT.

Please see Book 1 for an overview of the RD4X and system design considerations.

See Book 2 for product and performance specifications.

See Book 3 for the mechanical installation of the RD4X.

See Book 5 for control system connections, VFD adjustment, Start-Up, Commissioning or Maintenance.

This book does not cover overall system design or system integration issues. Some of these issues are discussed in Books 1 and 5, but in general, **specification documents provided by a qualified specifying engineer are to be considered the Basis of System Design.**

Following these instructions does not necessarily assure compliance with local codes and standards, which must always be observed.

Table of Contents

BOOK 1: Overview	
Product Features	2
De-Coupled and DOAS System Overview	3
RD4X Psychrometrics	4
System Integration	6
Critical Warnings	7
Checklist for Specifying Engineer	8
BOOK 2: Specifications	
Product Features	2
Available Features	3
Descriptive Drawings	4
Configuration Codes	6
Condensed Specifications	8
Dimensions	10
Corner Weights and Curb Dimensions	11
Ratings	13
Modes of Operation	21
Unit Controls and Operating Sequences	22
Connections to External Equipment	24
Guide Specifications	25
BOOK 3: Mechanical Installation	
Product Features	2
Order of Installation	3
Critical Dimensions	4
Curb and Rail Dimensions	5
Service Clearances	6
Curb/Rail Installation Considerations	7
Rigging Information	8
Securing Against Wind Loads	9
Ducting	10
Coils and Drain Connections	11
How to Reconfigure the Inlet and Outlet (opt.)	12
How to Install Field-Supplied Coil (opt.)	14
BOOK 4: Electrical Installation	
Product Features	2
Power Connections	3
Disconnect Switch Ratings	5
On-Board Transformer	6
Control Connections	7
Electrical Installation Checklists	8
Schematics	10
Ladder Schematics	17
BOOK 5: Start-Up, Commissioning and Maintenance	
Product Features	2
Initial Checks	3
Balance Air Flow	4
Review / Adjust On-Board Controls (opt.)	6
VFD Parameters	8
Control Connection Examples: On/Off and 3-speed	11
Analog Control of the VFDs -- General	16
Scaling to VFD Response to Analog Inputs	17
Control Connection Examples: Analog Controllers	22
Control Connection Examples: Analog and On/Off	35
To Reset VFD Parameters	39
Service Parts	40
Warranty Information	48
Records	49

BOOK 4: ELECTRICAL

PRODUCT FEATURES

The RD4X is an Energy Recovery Ventilator with available features designed for Dedicated Outdoor Air Systems.

Standard features include:

- Energy recovery by fixed-plate enthalpic energy exchanger
- Enthalpy- and temperature-controlled bypass of energy recovery
- Isolation dampers that shut down when ventilation is not needed
- Variable-Frequency Drive (VFD)-controlled direct-drive fresh air and exhaust air blowers
- Integrated disconnect switch
- Airflow measurement stations

Available features include:

- Heating and/or cooling coils for post-treatment of fresh air
- Double-wall construction

PRINCIPLE OF OPERATION

The RD4X can operate in up to four modes depending on options installed:

- Energy Recovery mode: the unit transfers heating or cooling energy from the exhaust air to the fresh air.
- Recovery Bypass mode: the unit takes advantage of free cooling from the outside air and doesn't transfer energy between air streams.
- Dehumidification mode: the unit conditions the fresh air to 53°F.
- Heating mode: the unit tempers the fresh air to 75°F.

The RD4X operates automatically. The unit receives an external call for ventilation. Its isolation dampers open and turn on the variable frequency drives and blowers. The unit determines the operating mode by continuously monitoring the air streams for temperature and enthalpy.

The RD4X does not include a condensing unit, chiller, heat pump or boiler. When a coil for dehumidification or cooling is part of the RD4X unit, the condensing unit, chiller, heat pump or boiler is separately installed to meet the needs of the complete system. RD4X units equipped with coils include connection points to call for operation of the separate heating or cooling equipment. **However, no fluid or refrigerant flow control valve (TX valve) is provided, and must be specified by the designer of the overall system for separate sourcing.**

OPERATING CONTROLS

A wide variety of low voltage (24VAC) control schemes may be selected to meet the ventilation needs of the facility. These may include time clock, occupancy sensor, carbon dioxide sensor, and others. DDC

systems may also control the unit with external control by other. **TX valves are not provided.**

WARNING

RISK OF FIRE, ELECTRIC SHOCK, OR INJURY. OBSERVE ALL CODES AND THE FOLLOWING:

1. Before servicing or cleaning the unit, switch power off at disconnect switch or service panel and lock-out/tag-out to prevent power from being switched on accidentally. More than one disconnect switch may be required to de-energize the equipment for servicing.
2. This installation manual shows the suggested installation method. Additional measures may be required by local codes and standards.
3. Installation work and electrical wiring must be done by qualified professional(s) in accordance with all applicable codes, standards and licensing requirements.
4. Any structural alterations necessary for installation must comply with all applicable building, health, and safety code requirements.
5. This unit must be grounded.
6. Sufficient air is needed for proper combustion and exhausting of gases through the flue (chimney) of fuel burning equipment that might be installed in the area affected by this equipment. If this unit is exhausting air from a space in which chimney-vented fuel burning equipment is located, take steps to assure that combustion air supply is not affected. Follow the heating equipment manufacturer's requirements and the combustion air supply requirements of applicable codes and standards.
7. Use the unit only in the manner intended by the manufacturer. If you have questions, contact the manufacturer.
8. This unit is intended for general ventilating only. Do not use to exhaust hazardous or explosive materials and vapors. Do not connect this unit to range hoods, fume hoods or collection systems for toxics.
9. When cutting or drilling into wall or ceiling, do not damage electrical wiring and other hidden utilities.
10. If installed indoors this unit must be properly ducted to the outdoors.

CAUTION

To avoid motor bearing damage and noisy and/or unbalanced impellers, keep drywall spray, construction dust etc, out of unit.

BOOK 4: ELECTRICAL

POWER CONNECTIONS

All internal electrical components have been wired at the factory. It is only necessary to bring supply voltage, control wires, and wires to external equipment supplied by others to the unit.

Determine the voltage of the power supply for the unit. Before bringing power to the unit check unit nameplate to confirm it matches the voltage and phase of the power being supplied. Use conduit, strain reliefs, etc. as required by code to secure the field wiring. Field connections need to be accessible for inspection.

⚠ WARNING

Follow all applicable safety codes, such as NEC or CSA C22.1 Canadian Electric Code part 1!

MINIMUM SUPPLY WIRE RATINGS

WIRE SIZING:

Use Minimum Circuit Ampacity (MCA) rating on the Unit Nameplate as the basis for wiring sizing.

Wire insulation must have minimum 75°C rating.

Wire insulation must have minimum 600V rating.

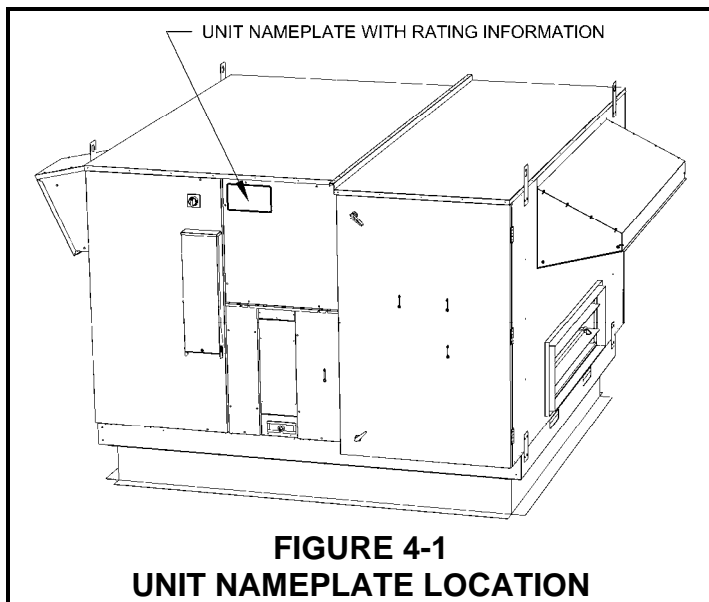

⚠ WARNING

Installation work and electrical wiring must be done by qualified professional(s) in accordance with all applicable codes, standards, and licensing requirements.

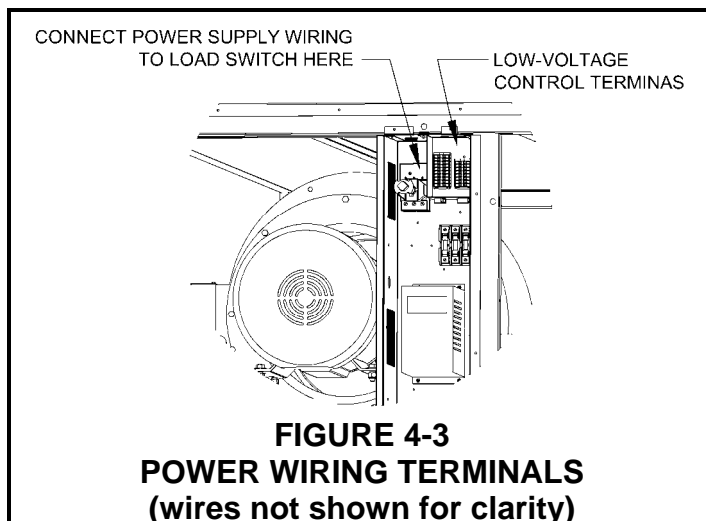
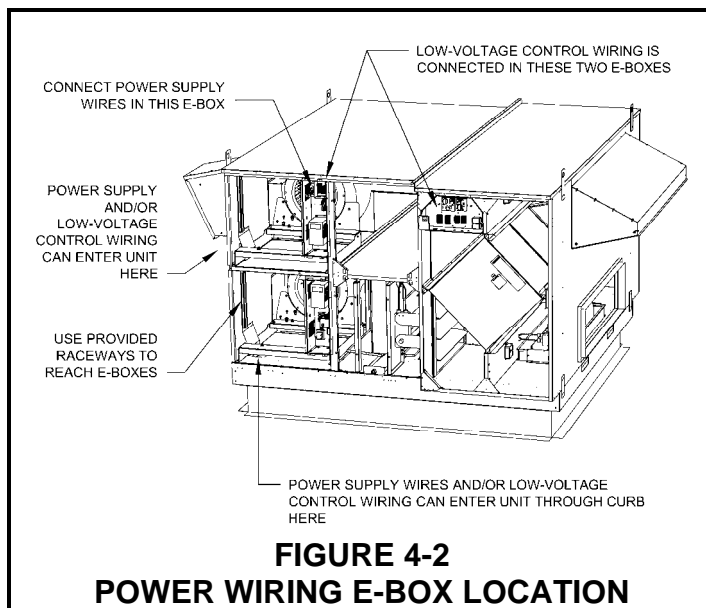

⚠ WARNING

Re-install the finger-safe guard after connecting the power supply conductors to the L1, L2 & L3 on the Disconnect Switch

BOOK 4: ELECTRICAL

POWER CONNECTIONS

Power and control wiring can enter the unit from either:

- Hole(s) drilled through the bottom of the unit at label location on access cover (Fig. 4-5);
or
- Hole(s) drilled through the side of the unit at label location (Fig 4-6).

Separate wiring raceways are provided in the unit blower compartment to route control and power wire to the top of the electrical enclosures.

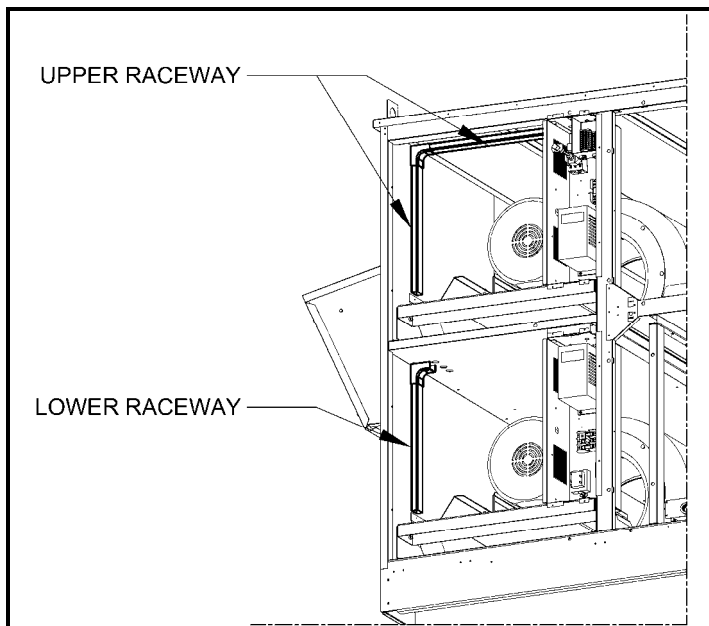

FIGURE 4-4
WIRING RACEWAY LOCATIONS IN BLOWER COMPARTMENT

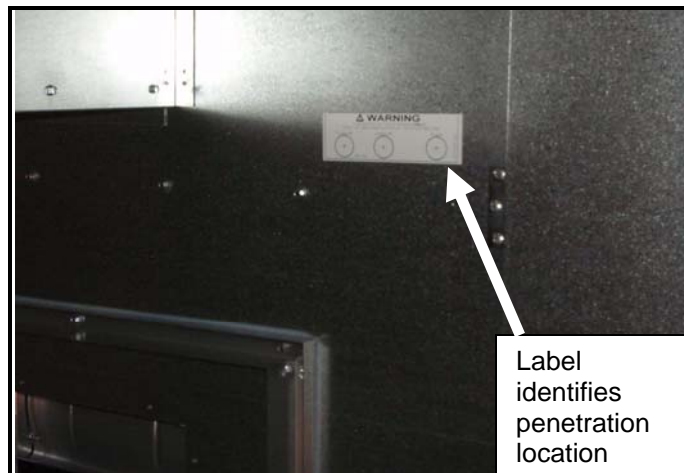

FIGURE 4-6
WIRE ENTRY THROUGH SIDE OF UNIT

Power wiring should be routed from the top of the smaller raceway through the larger bushing in the top of the high-voltage electrical box (Fig 4-7). Connect power wiring to the upper terminals of the disconnect switch. Re-install the finger-safe guard after connecting the power wiring.

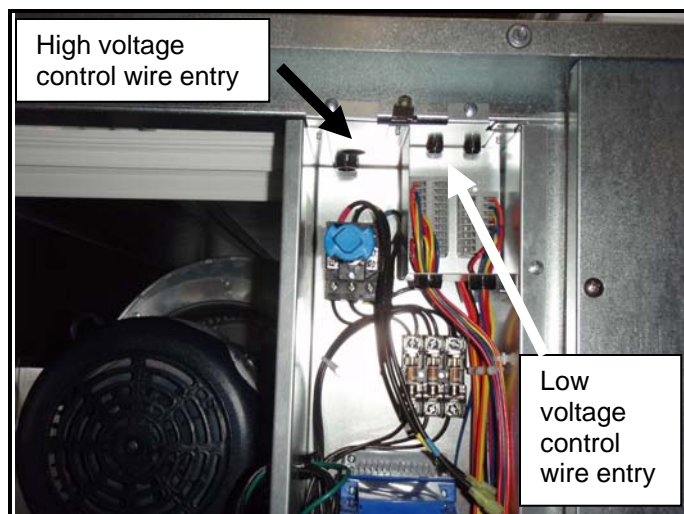

FIGURE 4-7
WIRE ENTRY INTO UPPER E-BOX

Low-voltage control wiring should be routed from the top of the larger raceway through the smaller bushings in the top of the low-voltage terminal enclosure (Fig 4-7).



FIGURE 4-5
WIRE ENTRY THROUGH BASE OF UNIT

BOOK 4: ELECTRICAL

DISCONNECT SWITCH RATINGS



White channel
at top of
center section

FIGURE 4-8
ROUTE CONTROL WIRES TO LOW-VOLTAGE E-BOX

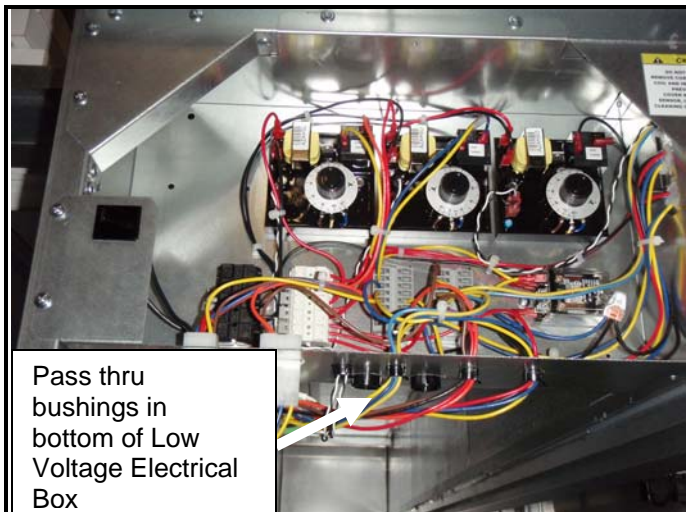

Pass thru
bushings in
bottom of Low
Voltage Electrical
Box

FIGURE 4-9
WIRE ENTRY INTO LOW-VOLTAGE E-BOX

DISCONNECT SWITCH RATINGS

RD4X unit has an integrated Disconnect Switch with a door interlock. The door covering the high-voltage and motor compartments cannot be opened without turning this Disconnect Switch to the "OFF" position.

Once the door is opened, the Disconnect Switch can be switched back to the "ON" position for trouble-shooting purposes.

Local codes may require installation of an additional Disconnect Switch.

RATINGS:	3Ø
VOLTAGE:	600VAC
AMPS:	40A
HORSE POWER:	10HP @ 240V
MAXIMUM WIRE SIZE:	6AWG

CHARACTERISTICS:

- Must be in OFF position to open Door covering high-voltage compartments.
- May be returned to ON position after Door is open.
- Must be in OFF position to close Door.
- Available Factory Option: Fuse Block
- Door covering low-voltage electrical compartment can be opened without turning disconnect switch to OFF position.
- When Disconnect Switch is in OFF position, voltage is still available at the L1, L2 and L3 terminals.

⚠ WARNING

Danger of Electrical Shock when servicing unit. ALWAYS DISCONNECT POWER SOURCE BEFORE SERVICING! More than one disconnect switch may be required. Proper wiring size selection and wiring installation are the responsibility of the electrical contractor.

⚠ WARNING

Danger of Electrical Shock! Variable Frequency Drive capacitors retain charge after power is removed. Disconnect power and wait a minimum of three minutes before servicing drive.

Do not cycle input power to drive more than once every two minutes.

BOOK 4: ELECTRICAL

ON-BOARD TRANSFORMER

The RD4X has an on-board transformer that provides a high-quality source of 24VAC Class 2 power source for low-voltage control systems. The transformer itself is designed to fail safely in the event of a catastrophic overload. In addition, a re-settable circuit-breaker protects the transformer from inadvertent short-circuits that could occur during connection of the low-voltage wiring. If an excessive load is placed on the transformer the circuit breaker will trip to prevent the failure of the transformer. When it trips the circuit breaker's button pops up, exposing a white mark. Shut off the primary-side power to the unit, and remove the excessive load or the short. The circuit breaker can be reset about fifteen seconds after it trips by pressing in the button.

CAUTION

UNITS WITH 230VAC POWER SUPPLY:

Unit is shipped with transformer set for 208VAC power supply. For 230VAC, move the black primary-side lead from the transformer's "208V" terminal to the transformer's "230V" terminal.

Do not move the black primary-side lead that is connected to the transformer's "COM" terminal.

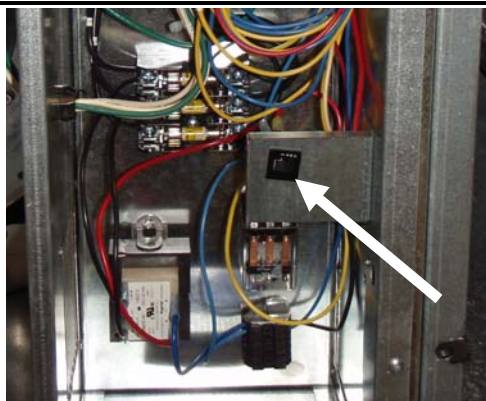

FIGURE 4-10
CIRCUIT BREAKER LOCATION IN BOTTOM E-BOX.

Limits of Power Output

If limits on wire gauge and length are observed, you may connect control devices that draw up to 8VA. More than one device can be connected as long as total steady-state load does not exceed 8VA.

Observe these limits to wire length and gauge in order to ensure reliable operation of the control system.

Wire Gauge	#22	#20	#18	#16	#14	#12
Circuit Length	40'	60'	100'	150'	250'	400'

"Circuit Length" is distance from RD2X to Control Device

BOOK 4: ELECTRICAL

CONTROL CONNECTIONS

The RD4X can be controlled by various devices including remote switch or relay, digital time clock with relay, occupancy sensor with relay, and carbon dioxide sensor with relay and analog output. These devices are commonly known as 2-wire, 3-wire, and 4-wire devices.

A terminal block in the low-voltage compartment in the RD4X **blower** section allows for connection of any control device. See the section on External Control Diagrams for connection of various control devices.



FIGURE 4-11
TERMINAL BLOCKS FOR CONTROL
DEVICE CONNECTION.

⚠ WARNING

Danger of Electrical Shock when servicing unit. ALWAYS DISCONNECT POWER SOURCE BEFORE SERVICING! More than one disconnect switch may be required. Proper wiring size selection and wiring installation are the responsibility of the electrical contractor.

⚠ WARNING

Installation work and electrical wiring must be done by qualified professional(s) in accordance with all applicable codes, standards, and licensing requirements.

BASIC UNIT CONTROL CONNECTIONS

2-wire controls: If the control requires no power to operate and acts like a simple on/off switch, use the red and yellow wires. Make no connection to the blue wire.

3-wire controls: If the control requires 24VAC power to operate, and has a third connection point (output) that goes hot when the control is calling for operation, connect the red and blue wires to the power inputs of the control, and connect the yellow wire to the output of the control. If the unit does not turn on when the control calls, reverse the red and blue wires.

4-wire controls: If the control requires 24VAC power to operate, and has third and fourth non-powered connection points (dry contacts) that make a circuit when the control is calling for operation, connect the red and blue wires to the power inputs of the control. Connect the yellow wire to one of the dry contacts, and install a jumper between the red wire and the other dry contact.

EXTERNAL EQUIPMENT CONNECTIONS

The RD4X provides “dry contact” connections to signal external equipment supplied by others. These signals include indication of Recovery Bypass mode, Dehumidification mode, Heating mode, and Filter Alarm (dependent on options chosen). Terminal blocks in the low-voltage compartment in the RD4X **core** section allows for these connections. See the section on Electrical Schematics for connection of these various signals.

The “dry contact” connection is provided through a relay rated 10A at 277VAC on the temperature controller.

ADVANCED OPERATING CONTROLS

A wide variety of low voltage (24VAC) control schemes may be selected by the engineer, installer, or owner to meet the ventilation needs of the facility. These may include time clock, occupancy sensor, carbon dioxide sensor, and others. DDC systems may also control the unit with external control by other. Most control schemes will operate the unit only when needed.

For additional details about advanced operating controls, see:

- **BOOK 2 – SPECIFICATIONS, pages 22-23,**
- **BOOK 5 – START-UP, COMMISSIONING AND MAINTENANCE, pages 11-37.**

BOOK 4: ELECTRICAL

ELECTRICAL INSTALLATION CHECKLISTS

PRE-START CHECKLIST

1. Turn the Disconnect Switch on the blower module to the "OFF" position and open the blower module door.
2. Verify the supply wire to the unit is the correct gage.
3. Verify the control wire to the unit is the correct gage.
4. In the blower module, check for obstructions in the blowers. Remove any foreign objects.
5. Rotate the blower wheels. They should rotate freely. Check for rubbing.
6. Check the blower wheels are secure on the motor shaft.
7. Open the core module door.
8. In the core module, check for obstructions to the dampers. Remove any foreign objects.
9. Close all doors.
10. Check that the unit is level.

BASIC UNIT OPERATION CHECK

The RD4X unit can be connected to various devices that provide an external call for ventilation (see CONTROL CONNECTIONS, page 7). The Basic Unit Operation Check should be performed BEFORE connecting controls.

1. For the Basic Unit Operation Check install a test switch to Terminals 2 (C) and 3 (NC) on the **left** terminal block in the top electrical box of the blower module. Install the test switch outside of the unit and close all doors. Disconnect any external controls.
2. With the test switch in the "off" or "open" position, apply power to the unit. Remove the inverter covers in the blower door. The VFD displays should be lit. The unit should not operate.
3. Change Parameter 140 (P140) to 12 on the top (EA) VFD. This enables the relay output of the VFD. See section "TO CHANGE VFD PARAMETER P140" on the next page to change P140.
4. Close the test switch. The VFDs/motors/blowers should not turn on immediately. The isolation dampers are opening inside the unit. It will take less than 60 seconds for the dampers to open. Once they open the VFDs will automatically turn on. This is indicated by the blowers starting and the VFD displays showing increasing hertz.
5. Within 10 seconds the motors should be at factory preset speed (typically 45 hertz).

(Continued next page)

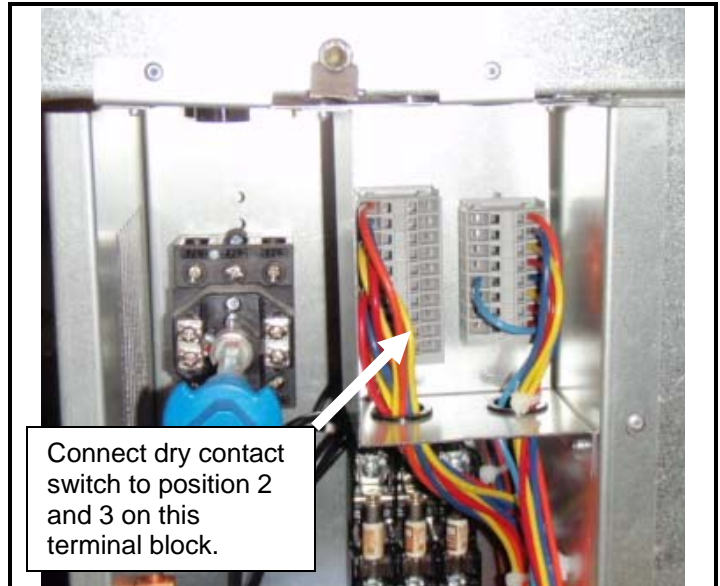

FIGURE 4-12
CONNECTION OF TEST SWITCH

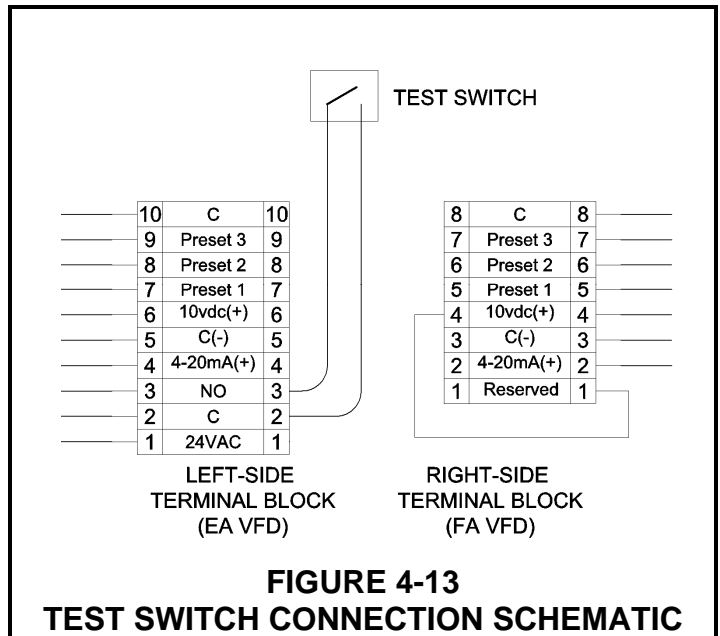

FIGURE 4-13
TEST SWITCH CONNECTION SCHEMATIC

⚠ WARNING

Danger of Electrical Shock when servicing unit. ALWAYS DISCONNECT POWER SOURCE BEFORE SERVICING! More than one disconnect switch may be required. Proper wiring size selection and wiring installation are the responsibility of the electrical contractor.

BOOK 4: ELECTRICAL

ELECTRICAL INSTALLATION CHECKLISTS

BASIC UNIT OPERATION CHECK (cont.)

6. With the unit operating at the factory preset speed, and doors closed, check the operating voltage and amperage at each VFD (see TO VIEW VFD VOLTS AND AMPS, this page).
7. Confirm that each VFD is operating within the voltage and amperage range indicated for the motor it controls (see Unit Nameplate).
8. Take corrective action if necessary. If motor voltage is correct, but current is too high, reduce the VFD speed setting (see TO CHANGE VFD SPEED, below).
9. Turn off the test switch, and disconnect power to the unit.
10. Open door and remove the test switch. Close door.

WARNING

Danger of Electrical Shock! Door-mounted Disconnect Switch interrupts power to the unit when in the OFF position, but line voltage is still present at the L1, L2 & L3 terminals of the load switch. These terminals are covered by a finger-safe guard. MAKE SURE THE FINGER-SAFE GUARD IS IN PLACE!

TO CHANGE VFD PARAMETER P140

- Note:** This is only required on the EA VFD (top VFD).
1. VFD must be powered up – something will be showing on the LED display.
 2. Push the “M” or MODE button – PASS will flash on screen followed by “0000”.
 3. Press and hold UP Arrow to scroll to password 225.
 4. Press MODE to display P100.
 5. Use UP Arrow to scroll to parameter P140.
 6. Press MODE to display Parameter value.
 7. Use UP Arrow to change parameter value to 12.
 8. Press MODE to display STOP (in some cases the display will be different).

TO VIEW VFD VOLTS

1. VFD must be powered up – something will be showing on the LED display.
2. Push the “M” or MODE button – PASS will flash on screen followed by “0000”.
3. Push MODE button again to display P500 (displayed parameter may vary).
4. Use UP or DOWN arrows to scroll to Parameter P506 (Motor Voltage).
5. Press MODE button to view the Motor Voltage.
6. Press MODE to exit.

TO VIEW VFD AMPS

1. VFD must be powered up – something will be showing on the LED display.
2. Push the “M” or MODE button – PASS will flash on screen followed by “0000”.
3. Push MODE button again to display P500 (displayed parameter may vary).
4. Use UP or DOWN arrows to scroll to Parameter P508 (Motor Current).
5. Press MODE button to view the Motor Current.
6. Press MODE to exit.

TO CHANGE VFD SPEED

1. VFD must be powered up – something will be showing on the LED display.
2. If speed is not displayed, push the “M” or MODE button until speed is displayed in hertz: for example, “60.0”.
3. Press the UP or DOWN arrows to change the operating speed.

TO RESET VFD PARAMETERS TO FACTORY SETTING USING KEYPAD

1. VFD must be powered up – something will be showing on the LED display.
2. Push the “M” or MODE button – PASS will flash on screen followed by “0000”.
3. Press and hold Up Arrow to scroll to password 1234
4. Press MODE to display P100
5. Use Up Arrow to scroll to Parameter 199
6. Press Mode again to display 00
7. Use up button to reach 02
8. Press MODE button to display STOP (in some cases the display will be different).
9. Turn VFD power off, wait thirty seconds, then turn VFD back on.

WARNING

Danger of Electrical Shock! Variable Frequency Drive capacitors retain charge after power is removed. Disconnect power and wait a minimum of three minutes before servicing drive.

Do not cycle input power to drive more than once every two minutes

BOOK 4: ELECTRICAL

SCHEMATICS

FIGURE 4-14: KEY TO SCHEMATIC LOCATIONS.

APPLIES TO: All RD4XRT Units.

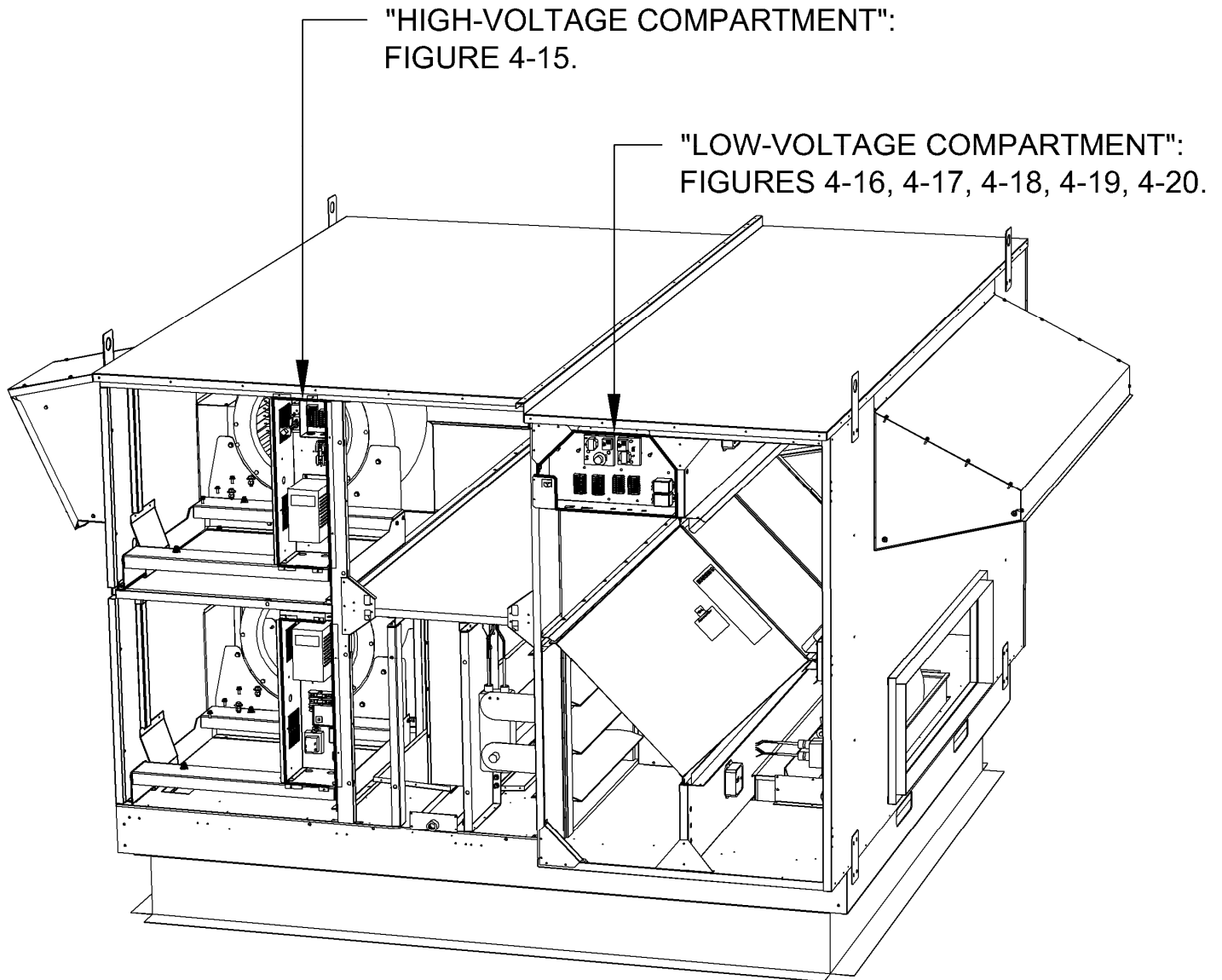

BOOK 4: ELECTRICAL SCHEMATICS

FIGURE 4-15. THREE-PHASE HIGH VOLTAGE COMPARTMENT.

HIGH VOLTAGE WIRING RD THREE PHASE UNIT

INPUT POWER
208-230/460/575 3
DEPENDING ON UNIT
CONFIGURATION

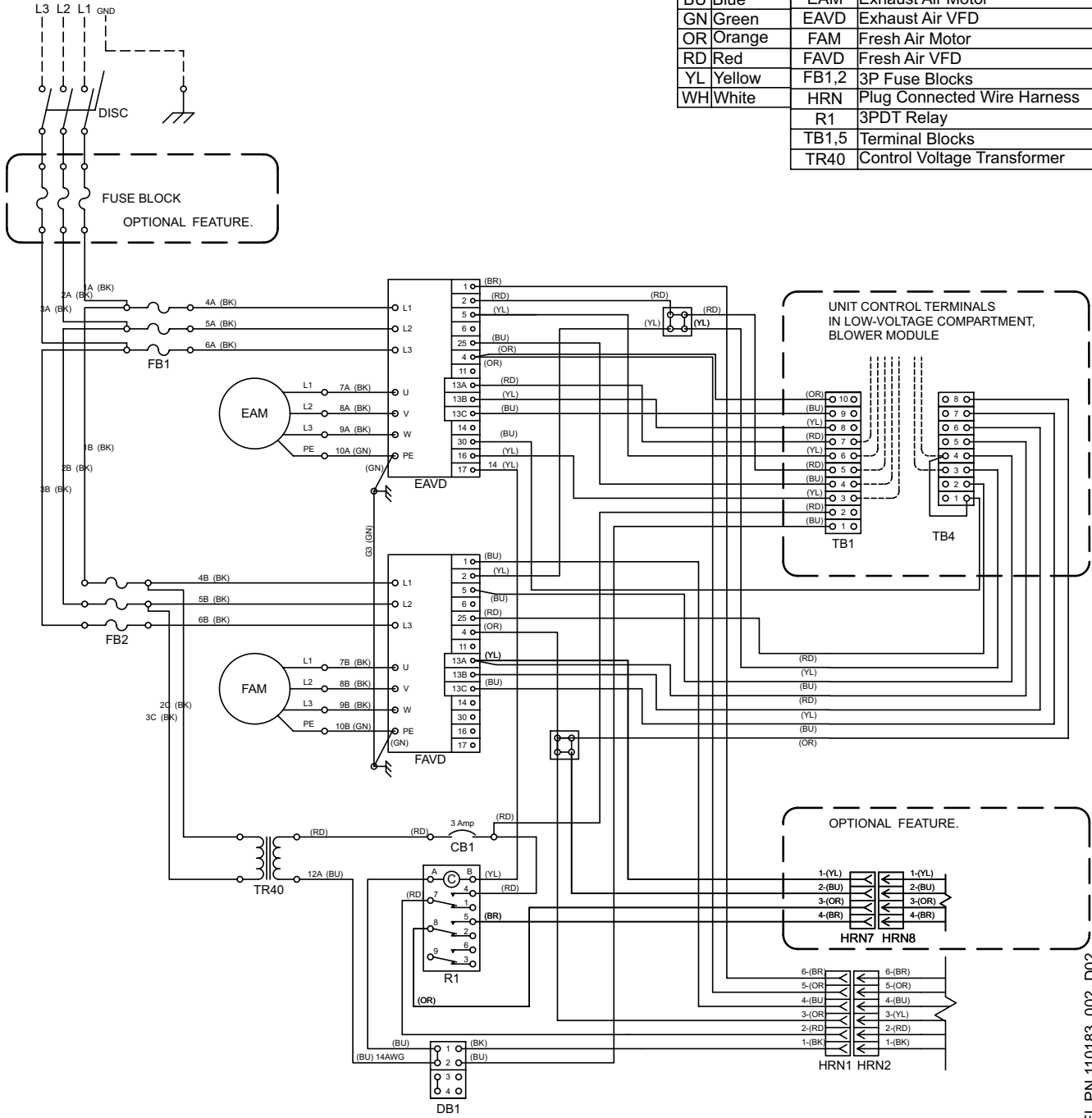

Color Legend	Legend
BK Black	CB1 Circuit Breaker
BR Brown	DB Wire Connector
BU Blue	DISC 3P Disconnect
GN Green	EAM Exhaust Air Motor
OR Orange	EAVD Exhaust Air VFD
RD Red	FAM Fresh Air Motor
YL Yellow	FAVD Fresh Air VFD
WH White	FB1,2 3P Fuse Blocks
	HRN Plug Connected Wire Harness
	R1 3PDT Relay
	TB1,5 Terminal Blocks
	TR40 Control Voltage Transformer

LABEL PN 110183_002_D02

BOOK 4: ELECTRICAL SCHEMATICS

FIGURE 4-16. LOW VOLTAGE COMPARTMENT – BASIC UNITS.

LOW VOLTAGE WIRING RD UNITS WITH NO HEATING OR COOLING COILS

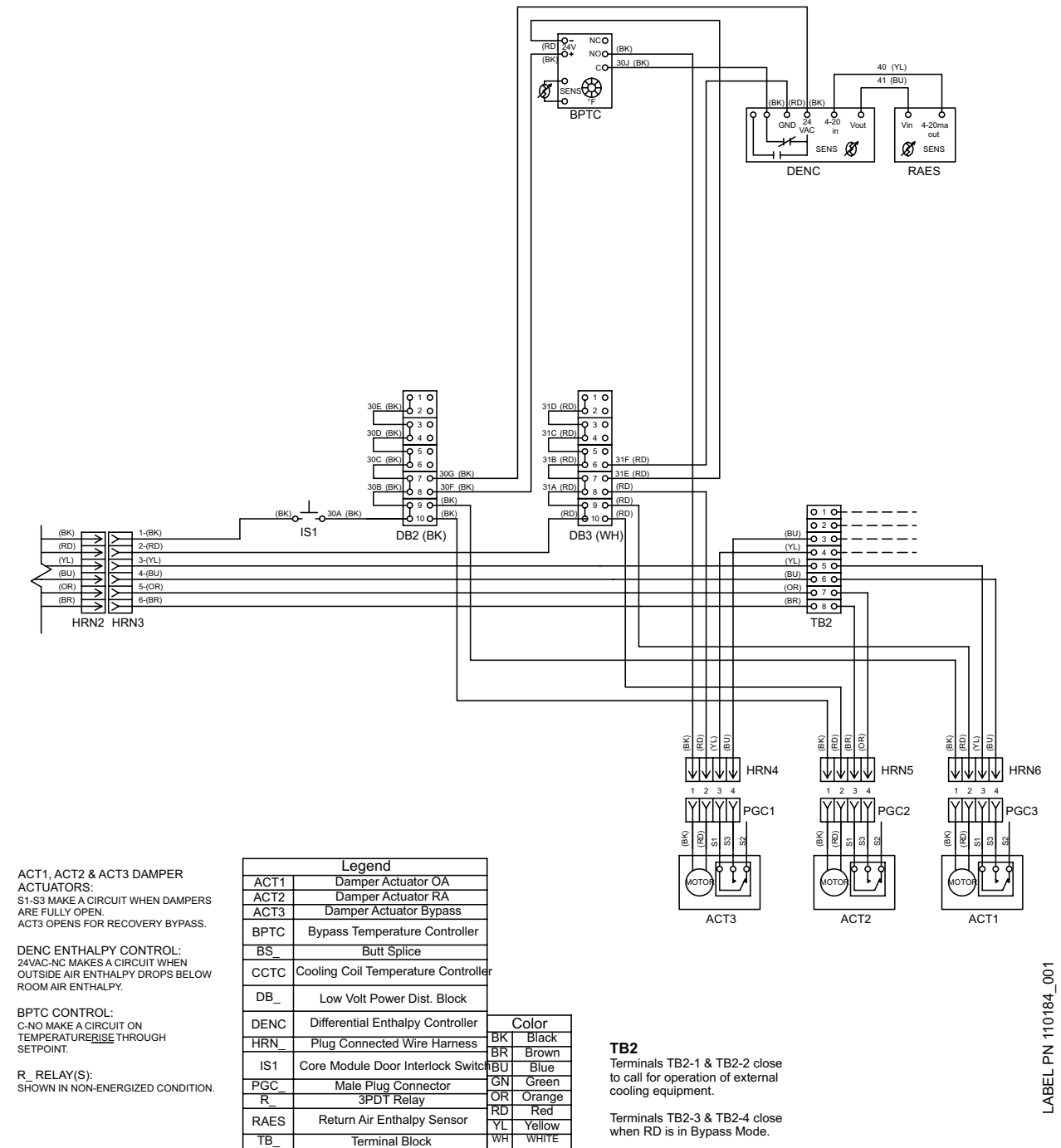

LABEL PN 110184_001

BOOK 4: ELECTRICAL SCHEMATICS

FIGURE 4-17. LOW VOLTAGE COMPARTMENT – DEHUMIDIFICATION UNITS.

LOW VOLTAGE WIRING RD UNITS WITH DEHUMIDIFICATION COILS

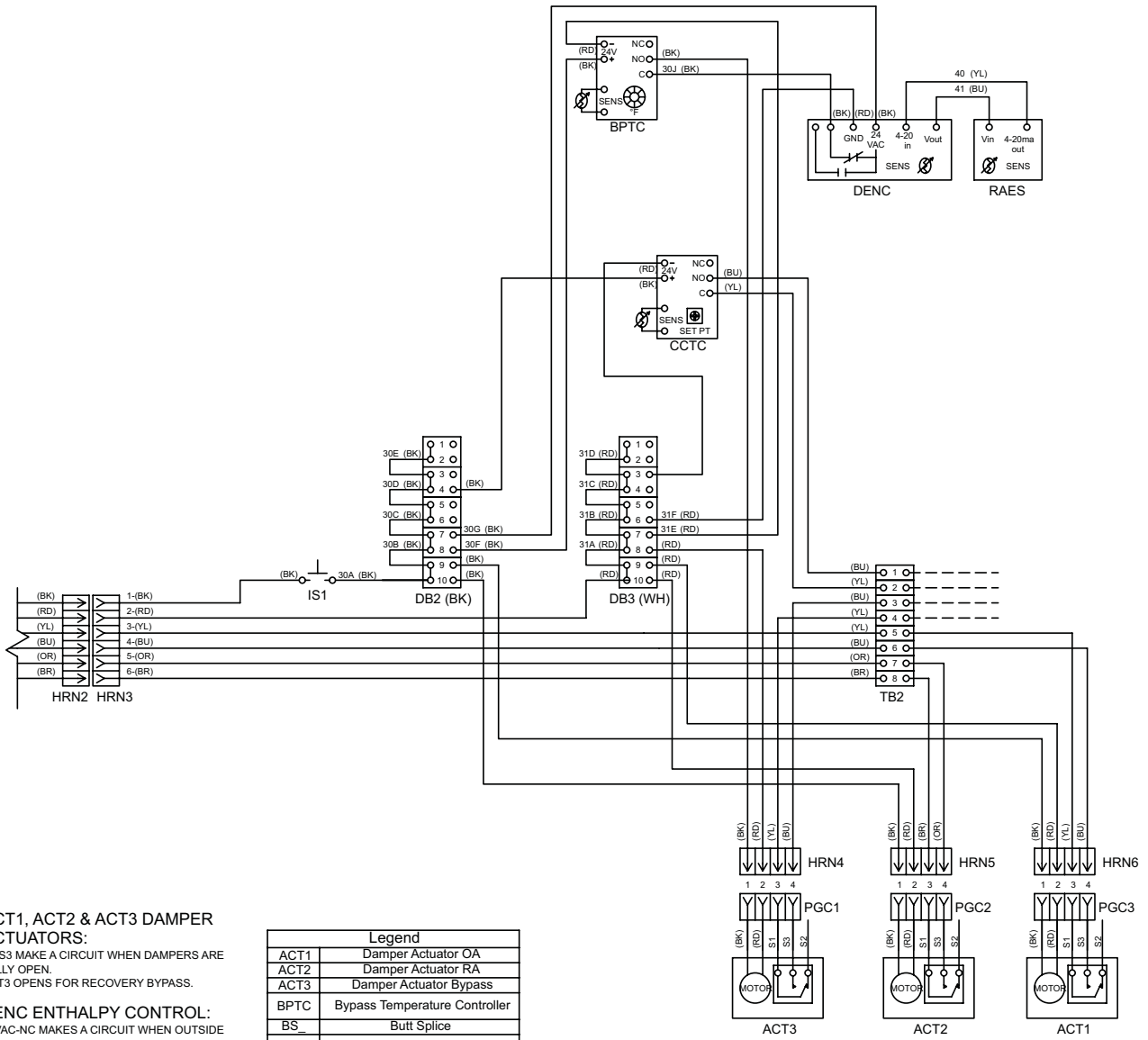

ACT1, ACT2 & ACT3 DAMPER ACTUATORS:
 S1-S3 MAKE A CIRCUIT WHEN DAMPERS ARE FULLY OPEN.
 ACT3 OPENS FOR RECOVERY BYPASS.

DENC ENTHALPY CONTROL:
 24VAC-NC MAKES A CIRCUIT WHEN OUTSIDE AIR ENTHALPY DROPS BELOW ROOM AIR ENTHALPY.

BPTC CONTROL:
 C-NO MAKE A CIRCUIT ON TEMPERATURE RISE THROUGH SETPOINT.

R_ RELAY(S):
 SHOWN IN NON-ENERGIZED CONDITION.

CCTC CONTROL:
 C-NO MAKE A CIRCUIT ON TEMPERATURE (ALTERNATE DEWPOINT) RISE THROUGH SETPOINT

Legend		
ACT1	Damper Actuator OA	
ACT2	Damper Actuator RA	
ACT3	Damper Actuator Bypass	
BPTC	Bypass Temperature Controller	
BS	Butt Splice	
CCTC	Cooling Coil Temperature Controller	
DB_	Low Volt Power Dist. Block	
DENC	Differential Enthalpy Controller	
HRN_	Plug Connected Wire Harness	
IS1	Core Module Door Interlock Switch	
PGC_	Male Plug Connector	
R_	3PDT Relay	
RAES	Return Air Enthalpy Sensor	
TB_	Terminal Block	
		Color
		BK Black
		BR Brown
		BU Blue
		GN Green
		OR Orange
		RD Red
		YL Yellow
		WH White

TB2
 Terminals TB2-1 & TB2-2 close call for operation of external cooling equipment.
 Terminals TB2-3 & TB2-4 close when RD is in Bypass Mode.

LABEL PN 110185_001

BOOK 4: ELECTRICAL SCHEMATICS

FIGURE 4-18. LOW VOLTAGE COMPARTMENT – HEATING UNITS.

LOW VOLTAGE WIRING RD UNITS WITH HEAT COIL

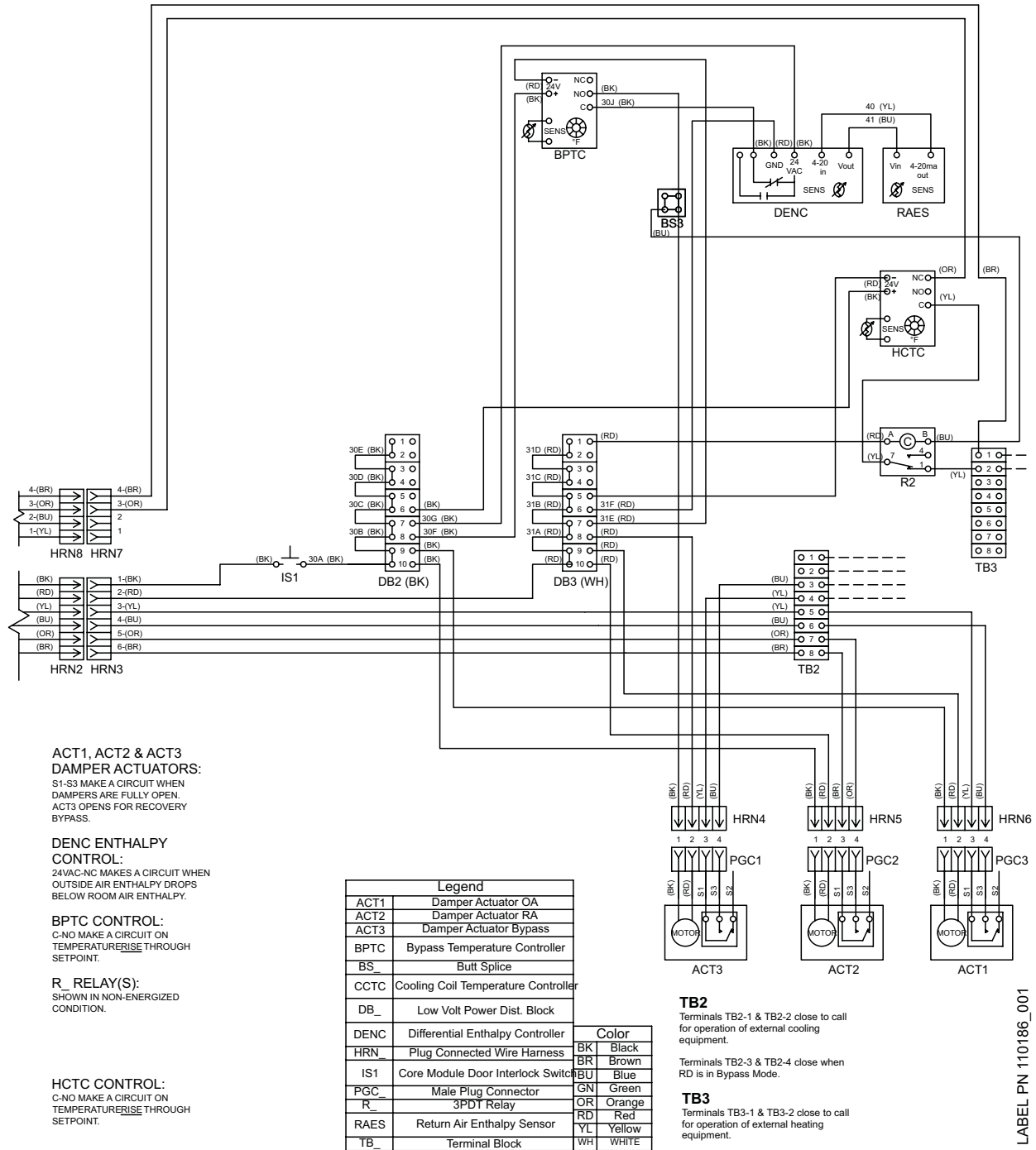

BOOK 4: ELECTRICAL SCHEMATICS

FIGURE 4-19. LOW VOLTAGE COMPARTMENT – DEHUMIDIFICATION & HEATING UNITS.

LOW VOLTAGE WIRING RD UNITS WITH HEAT AND DEHUMIDIFICATION COILS

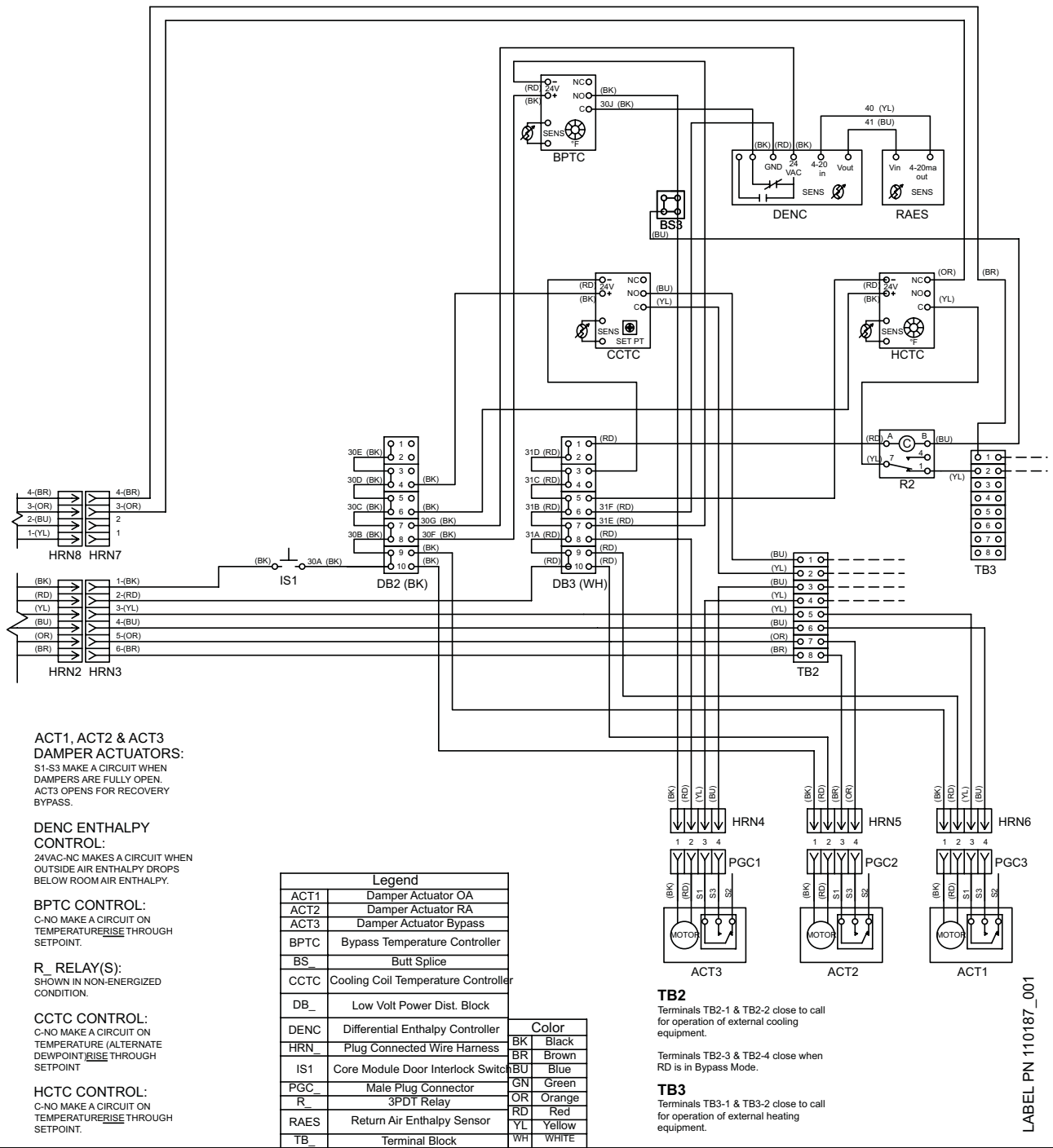

BOOK 4: ELECTRICAL

SCHEMATICS

FIGURE 4-20. LOW VOLTAGE COMPARTMENT – TERMINAL BLOCK CONNECTIONS FOR EXTERNAL EQUIPMENT.

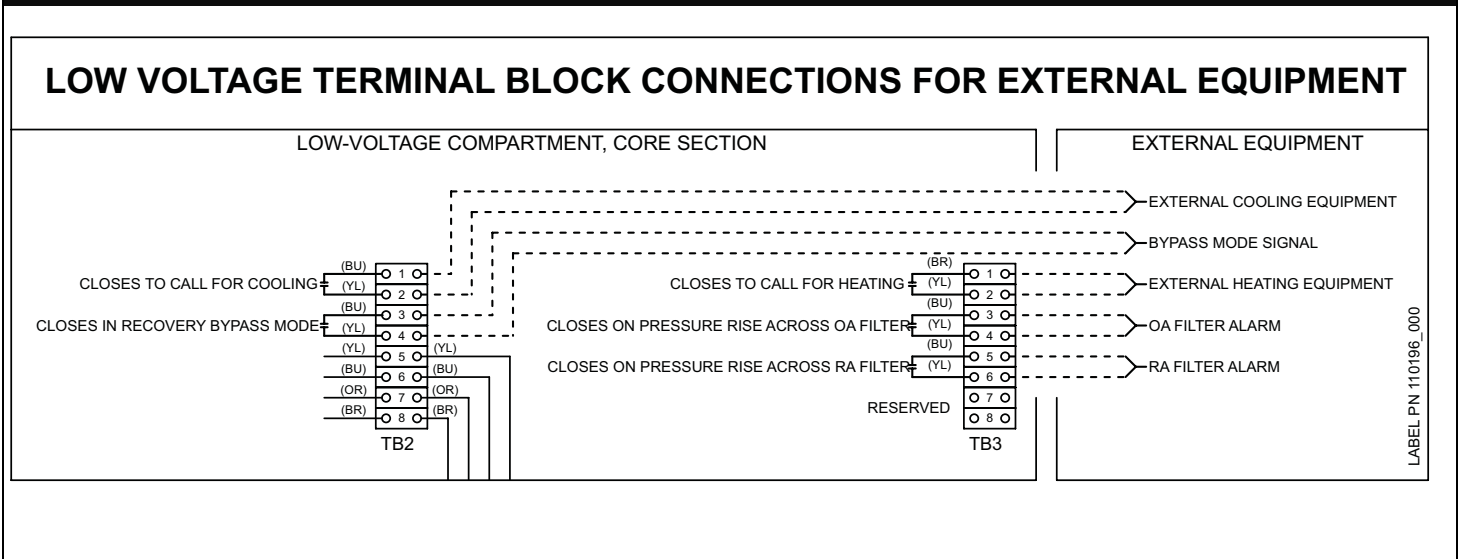

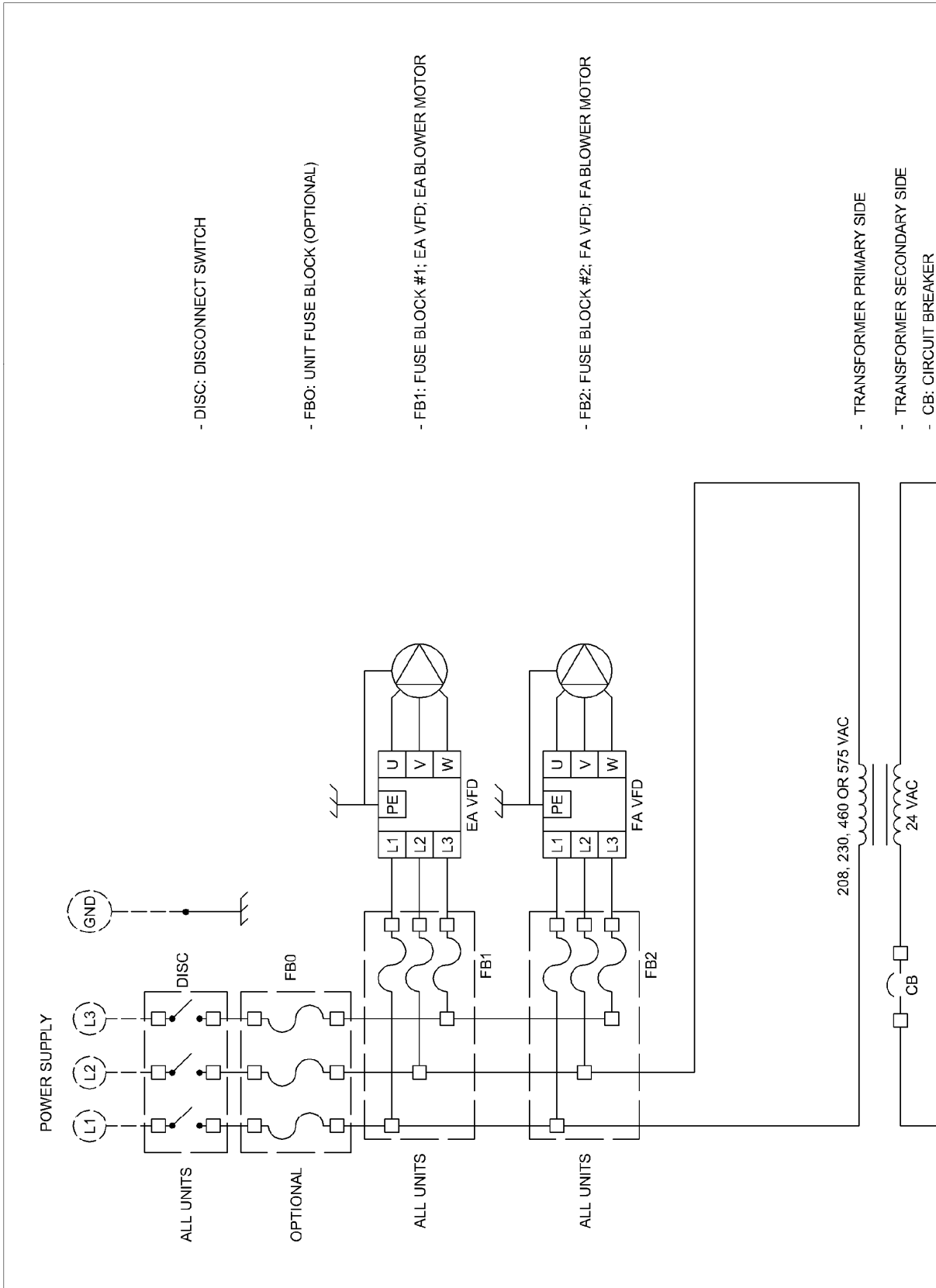

- DISC: DISCONNECT SWITCH

- FBO: UNIT FUSE BLOCK (OPTIONAL)

- FB1: FUSE BLOCK #1; EA VFD; EA BLOWER MOTOR

- FB2: FUSE BLOCK #2; FA VFD; FA BLOWER MOTOR

- TRANSFORMER PRIMARY SIDE

- TRANSFORMER SECONDARY SIDE

- CB: CIRCUIT BREAKER

FIGURE 4-21. HIGH VOLTAGE CIRCUITS (THREE-PHASE SHOWN)

Schematic continues in Figure 4-22.

BOOK 4: ELECTRICAL

LADDER SCHEMATIC

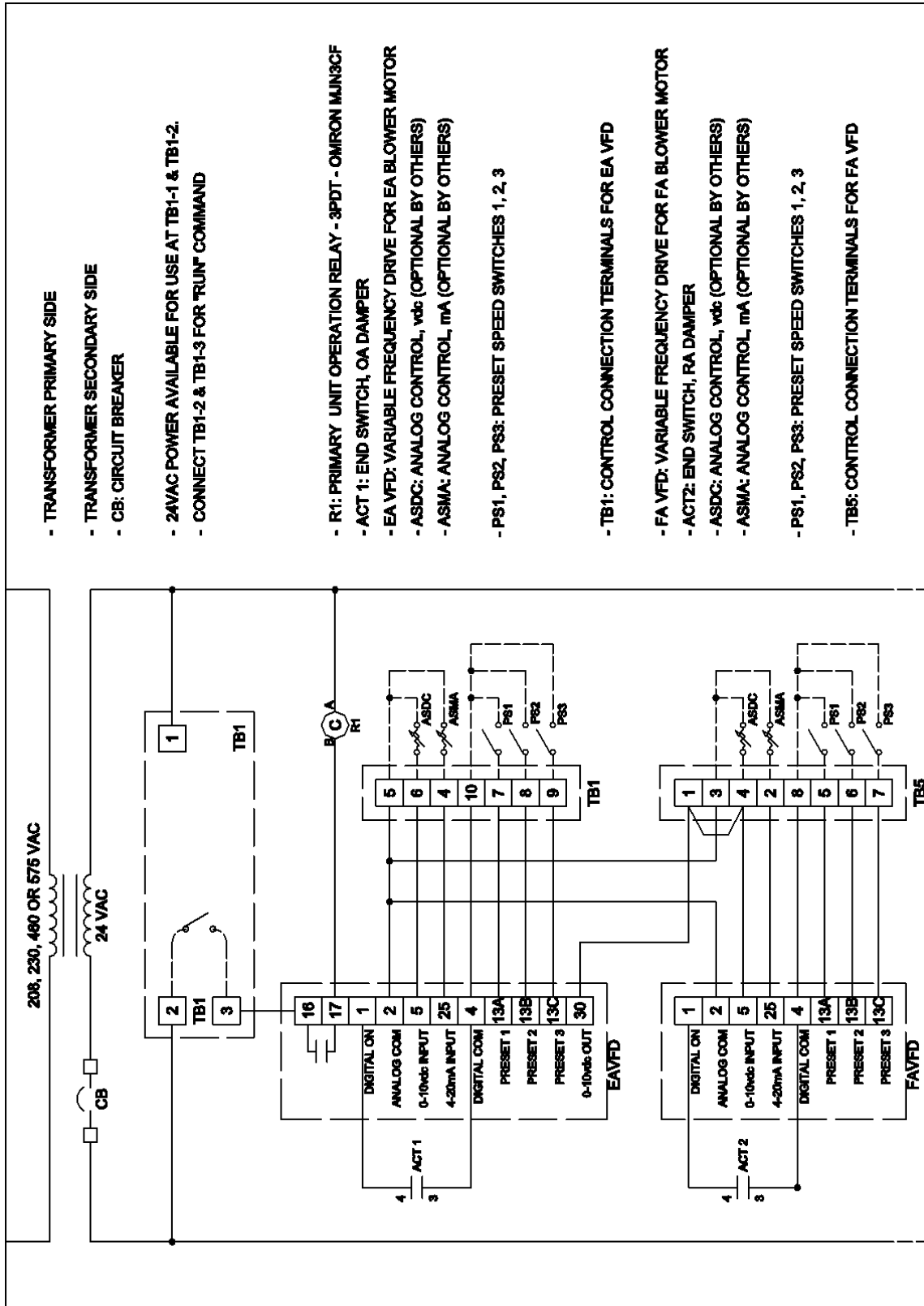

FIGURE 4-22. LOW VOLTAGE CIRCUITS (PART 1)

Schematic continues in Figure 4-23.

BOOK 4: ELECTRICAL

LADDER SCHEMATIC

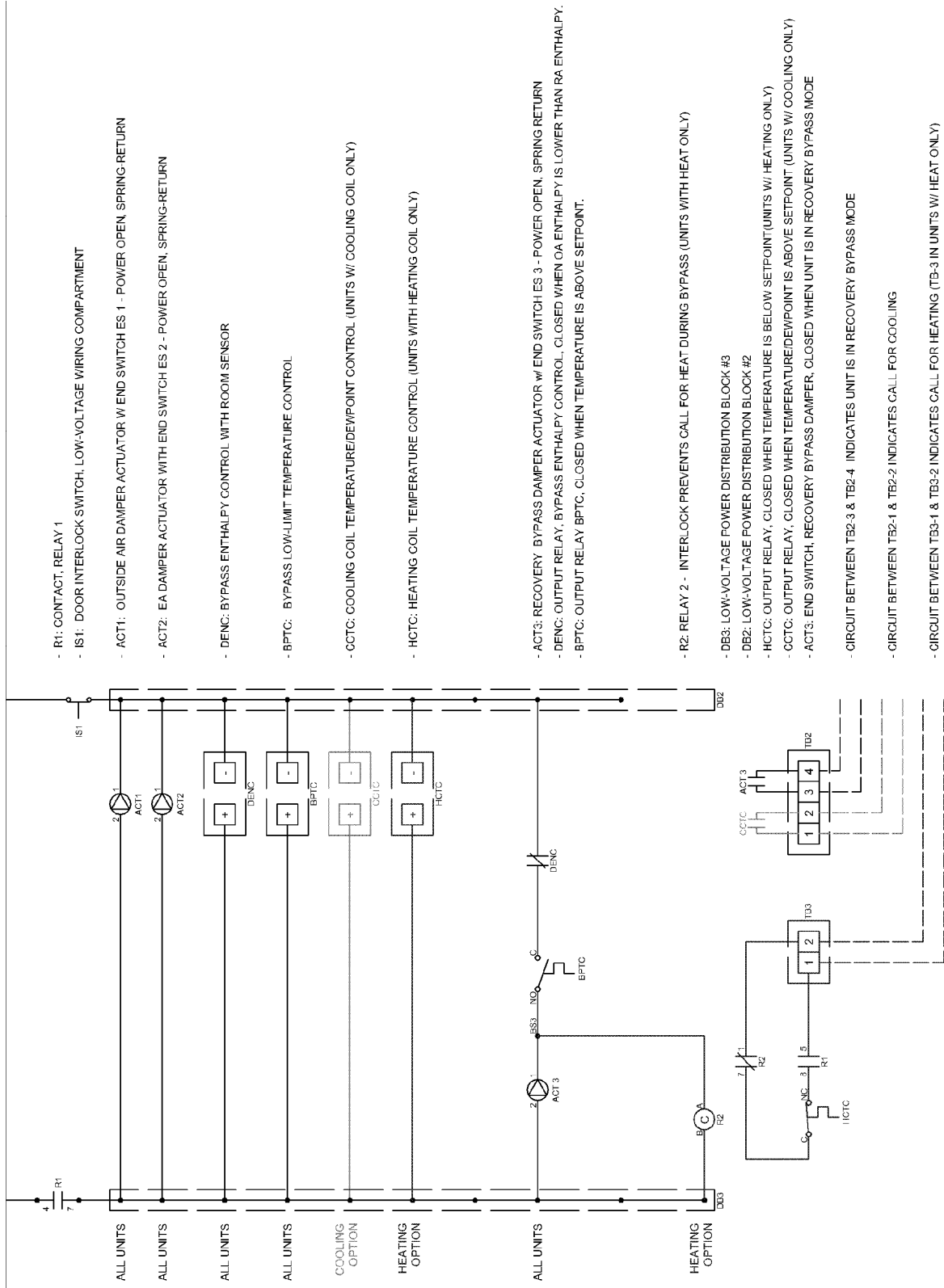

FIGURE 4-23. LOW VOLTAGE CIRCUITS (PART 2)

End of Schematic.

